

# पूर्व माध्यमिक शिष्यवृत्ती परीक्षा (इयत्ता 8 वी), मे 2021

बैठक क्र.

--	--	--	--	--	--	--	--	--	--

संच

A

0 1 2 2

पेपर क्र. - II

माध्यम : मराठी

वेळ : 1:30 ते 3:00

पृष्ठ : 32

तृतीय भाषा व बुद्धिमत्ता चाचणी

एकूण गुण : 150

प्रश्नपत्रिका सोडविण्यापूर्वी कृपया खालील सूचना काळजीपूर्वक वाचा :

- (1) या प्रश्नपत्रिकेत दोन विभाग आहेत. त्यापैकी विभाग I मध्ये तृतीय भाषा विषयासाठी 1 ते 25 व विभाग II मध्ये बुद्धिमत्ता चाचणी विषयासाठी 26 ते 75 असे एकूण 75 प्रश्न आहेत. सर्व प्रश्न सोडविणे आवश्यक आहे.
- (2) प्रत्येक प्रश्नासाठी 2 गुण आहेत.
- (3) प्रश्नपत्रिका सोडविण्यासाठी एकूण 90 मिनिटांचा कालावधी दिला जाईल.
- (4) उत्तरे नोंदविण्यासाठी स्वतंत्र उत्तरपत्रिका दिलेली आहे. प्रत्येक प्रश्नक्रमांकासमोर चार पर्यायासाठी क्रमागत वर्तुळे दिलेली आहेत. त्यातील अचूक उत्तराचा पर्याय क्रमांक असलेले वर्तुळ पुढील उदाहरणात दाखविल्याप्रमाणे रंगवा. उदा. प्रश्न क्र. 6 च्या बरोबर उत्तराचा पर्याय क्र. 2 असेल, तर तो पुढीलप्रमाणे नोंदवावा.  
प्रश्न क्र. 6      ① ● ③ ④
- (5) खालीलप्रमाणे नोंदविलेली उत्तरे ग्राह्य धरण्यात येणार नाहीत. असे उत्तर नोंदविल्यास त्या प्रश्नास 'शून्य' गुण दिले जातील.  
↓ ② ● ⊗
- (6) प्रश्नपत्रिकेत कमाल 20% प्रश्नांच्या बाबतीत उत्तरांच्या चार पर्यायांपैकी दोन पर्याय अचूक असतील ते दोन्ही पर्याय नोंदविणे बंधनकारक आहे. त्यासाठी त्या प्रश्नांच्या पुढे कंसात 'दोन अचूक पर्याय निवडा' अशी सूचना दिलेली आहे.
- (7) 'दोन अचूक पर्याय निवडा' अशी सूचना दिलेल्या प्रश्नाव्यतिरिक्त इतर प्रत्येक प्रश्नासाठी एकापेक्षा अधिक वर्तुळात नोंदविलेली उत्तरे व खाडाखोड करून नोंदविलेली उत्तरे ग्राह्य धरण्यात येणार नाहीत.
- (8) एकदा नोंदविलेली उत्तरे पुन्हा बदलता येणार नाहीत.
- (9) पर्यायाची उत्तरे नोंदविताना फक्त काळ्या किंवा निळ्या रंगाच्या बॉलपेनचाच वापर करावा. पेन्सिलने नोंदविलेली उत्तरे ग्राह्य धरण्यात येणार नाहीत.
- (10) प्रश्नपत्रिकेत प्रत्येक पानावर खाली व शेवटच्या पानावर कच्चे काम करण्यासाठी मोकळी जागा आहे, तेथेच कच्चे काम करावे.
- (11) परीक्षेस मर्यादित वेळ असल्याने एखाद्या प्रश्नाचे उत्तर तुम्हाला येत नसल्यास पुढील प्रश्न सोडवा. शेवटी वेळ शिल्लक राहिल्यास उरलेल्या प्रश्नांसाठी पुन्हा प्रयत्न करावा.
- (12) एखाद्या प्रश्नात त्रुटी/चूक आढळल्यास त्याबाबत पर्यवेक्षक किंवा परीक्षा केंद्रसंचालक यांच्याकडे विचारणा करू नये.
- (13) प्रश्नातील त्रुटी/चूक/आक्षेपाबाबतचे निवेदन शाळेत किंवा पालकांनी गटशिक्षणाधिकारी किंवा शिक्षणाधिकारी यांच्याकडे लेखी स्वरूपात न पाठवता संबंधित शाळेच्या लॉगीन मधून ऑनलाईन पद्धतीनेच पाठवावे.
- (14) त्रुटी/चूक/आक्षेपाबाबतचे निवेदन ऑनलाईन पद्धतीने पाठविण्याची मुदत परीक्षा परिषदेच्या संकेतस्थळावर अंतरिम (तात्पुरती) उत्तरसूची प्रसिद्ध झाल्यापासून 10 (दहा) दिवसांपर्यंत राहिल.
- (15) मुद्रणदोष किंवा अन्य कारणांमुळे प्रश्न चूकीचा असल्याचे आढळल्यास तज्ञ समितीच्या अभिप्रायानुसार योग्य ती कार्यवाही केली जाईल.
- (16) मूळ माध्यमासोबत इंग्रजी भाषेतील प्रश्नपत्रिका दिलेली आहे. मूळ माध्यमातील संदिग्ध प्रश्नांबाबत इंग्रजी प्रश्न पहावेत.

**Instructions for Q. 01 to Q. 03**

**Read the passage and choose the correct option :**

I was nineteen when I saw my first tiger in the wild, and it was every bit as trilling as I had imagined. I was in Kanha Tiger Reserve in Madhya Pradesh, seated on a young tame elephant that was barely six feet tall. The elephant and its teenage mahout were being trained to track tigers. I sat behind the boy mahout and hung on to a rope. Suddenly, a sight of cute tiger caught my eye. There behind the narrow path, sat a handsome young tiger. For a heart - stopping moment, we looked each - other with mutual surprise.

- 01.** The writer saw his first tiger at the age of .....
- (1) 13                      (2) 90                      (3) 19                      (4) 20
- 02.** Choose the correct two options.  
Where did the boy notice the cute tiger?
- (1) in the kanha tiger reserve                      (2) near the elephant  
(3) behind the narrow path                      (4) in front of the mahout
- 03.** Choose the two correct options.  
Who was trained to track the tigers?
- (1) the elephant      (2) the mahout      (3) the tiger      (4) the boy

**SPACE FOR ROUGH WORK**

04. Choose the correct option.

The climate of Chennai is hotter than the climate of Bangalore.

In the above sentence the comparison is about .....

- (1) Chennai (2) Bangalore  
(3) Climate of the city (4) City

05. Look at the following picture of clock and find out one correct alternative.

The clock shows .....

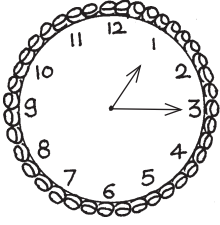

- (1) quarter past 3  
(2) quarter to 2  
(3) quarter past 1  
(4) quarter to 3

06. Choose one correct alternative from the following option.

The scientific study of metals and their uses means .....

- (1) allurgy (2) metallurgy (3) chemistry (4) extract

07. Find out the words which is related to 'parts of plants' leaves, flowers, stem.....

- (1) bark (2) feather (3) horn (4) soil

08. Read the following sentence and choose one correct alternative of the underlined phrase.

When teacher announced holiday, all the students sprang up from the benches.

- (1) return to original place (2) quick m  
(3) cheerful (4) particular season

कच्च्या कामासाठी फक्त

09. Read the following responses in the following web choose the correct alternative.

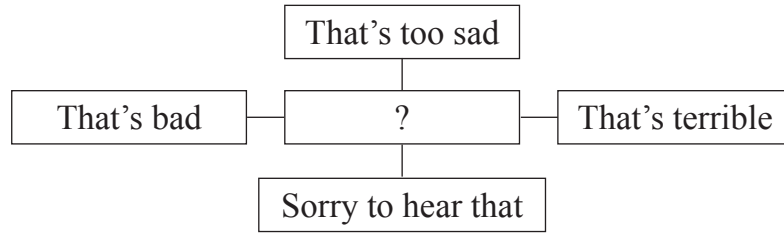

- (1) good news (2) appeal to save water  
(3) victory (4) bad news

10. Choose one correct alternative.

What is it ? - Which begins with 'T', ends with 't', and has  in it?

- (1) time (2) tea-pot (3) pot (4) tea

**Instructions for question no. 11 and 12**

Read the advertisement and choose one correct alternative.

***Time for 'Back to School'***  
Don't wait, come fast  
Fill up your pouches with .....

get pens, pencils, erasers, pro-circles,  
whiteners, stickers etc.

At knowledge stores  
**Contact us - [www.kst.com](http://www.kst.com)**

**Our features**  
1) good quality  
2) reasonable rate  
3) no exchange  
4) no discounts

11. Choose the correct option.

What is the name of the store?

- (1) Knowledge store (2) Don't wait, come fast  
(3) Fill up pouches (4) Back to school

SPACE FOR ROUGH WORK

12. How much discount we get on - pens, pencils etc?  
(1) 10% (2) 20% (3) no discounts (4) 50%

13. Choose one correct alternative.

Find out the object and its colour from the grid.

B	A	C
P	P	M
E	P	A
A	L	L
R	E	D

- (1) APPLE - RED  
(2) MANGO - YELLOW  
(3) PEAR - GREEN  
(4) CHILLI - GREEN

14. Choose two options from the following tree diagram of wrong pairs.

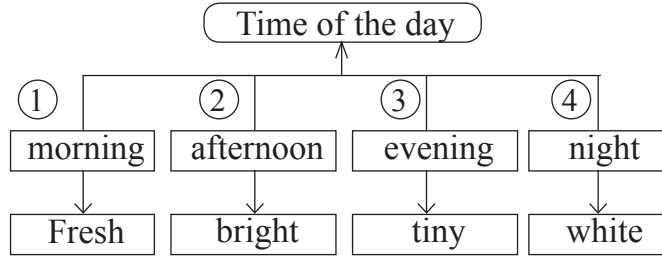

- (1) 4 (2) 2 (3) 3 (4) 1

15. Choose one correct alternative for the underlined word.

Ruby's teacher suggested to practise a lot of exercises.

It was a good advice.

- (1) noun (2) verb (3) adjective (4) adverb

16. Choose the alternative. Which word is wrongly used in the following question.

Do she recognize her childhood friend?

- (1) recognize (2) friend (3) do (4) childhood

कच्च्या कामासाठी फक्त

17. Read the following sentence and find out the type of sentences. Choose one correct answer.

Sancho Panza said, "God bless me!"

- (1) Imperative sentence (2) Exclamatory sentence  
(3) Assertive sentence (4) Interrogative sentence

18. Choose the correct alternative to complete the sentences.

Sakshi and her friends have lot of homework to complete. So they ..... not come to party.

- (1) might (2) need (3) may (4) do

19. Complete the following sentence using simple past tense. Choose one correct alternative.

Once upon a time there was a girl called Alyonushka. Alyonushka ..... with her parents and baby brother.

- (1) live (2) lived (3) will live (4) lives

20. Find out the sentence which is not in active voice. Choose the correct option

- 1) Honey is made by bees  
2) I saw him opening the box.  
3) I was offered a chair  
4) The letter was written by the clerk.

- (1) 4 (2) 2 (3) 1 (4) 3

21. Complete the sentence using correct alternative.

The teacher said that the earth ..... round the sun.

- (1) go (2) had gone (3) goes (4) will go

**SPACE FOR ROUGH WORK**



**Instructions for question no. 22 and 23**

**Read the passage and choose the correct alternative.**

Wikipedia is called the free encyclopedia. You don't have to buy it from the shop, borrow it from a library or pay any money to be able to read it on the net. At one click of the mouse, it is there for you to read. It is available on the world wide web (www). It contains information on thousands of topics in form of articles. Wikipedia is operated by the Non-profit Wikipedia Foundation.

22. Wikipedia is easily available at .....
- (1) shop                      (2) library                      (3) mall                      (4) net
23. The information on wikipedia is .....
- (1) in form of couplets                      (2) in form of dialogues  
(3) in form of articles                      (4) in form of table
24. Choose the correct option.  
'Drop everything and read,  
It's an access towards success' This slogan is related to .....
- (1) plants                      (2) library                      (3) reading                      (4) fame
25. Choose the correct option.  
Bina sent message, "How was your exam?"  
She got an answer, 'ez' can you guess the meaning?
- (1) easily                      (2) with ease                      (3) easy                      (4) difficult

कच्च्या कामासाठी फक्त

A B C D E | F G H I J | K L M N O | P Q R S T | U V W X Y

**SECTION - II**

**INTELLIGENCE TEST**

**Q. 26 and 27 :**

Use the given number series.

2 3 5 7 2 4 6 7 3 2 8 2 9 4 3 5 7 1 2 6

26. In the given number series how many times the sum of two adjacent numbers gives a prime number?  
(1) Six (2) Seven (3) Five (4) Eight
27. Which number occurs maximum times in the given series?  
(1) 7 (2) 3 (3) 4 (4) 2
28. Form a meaningful word from the letters 'R E O M'. What is the position of the letters in this word which is used to indicate the word 'Options'?  
(1) fourth, second (2) second, third  
(3) first, fourth (4) first, third
29. In the given alphabet series which letter is seventh to the left of the letter which is eighth from the right side of the series?  
(1) K (2) O (3) M (4) A

**SPACE FOR ROUGH WORK**



**SECTION - II**

**बुद्धिमत्ता चाचणी**

प्र. क्र. 26 व 27 साठी सूचना -

पुढे दिलेल्या अंकमालेचा वापर करा.

अंकमाला	2	3	5	7	2	4	6	7	3	2	8	2	9	4	3	5	7	1	2	6
---------	---	---	---	---	---	---	---	---	---	---	---	---	---	---	---	---	---	---	---	---

26. दिलेल्या अंकमालेत लगतच्या दोन अंकांची बेरीज मूळ संख्या येते, असे किती वेळा झाले आहे?
- (1) सहा (2) सात (3) पाच (4) आठ
27. दिलेल्या अंकमालेत सर्वाधिक वेळा कोणता अंक आला आहे?
- (1) 7 (2) 3 (3) 4 (4) 2
28. 'मा स क से ज व' या अक्षरांपासून तयार होणाऱ्या अर्थपूर्ण शब्दातील अनुक्रमे कोणत्या क्रमांकांच्या अक्षरांपासून 'खर्च' या शब्दाचा विरुद्धार्थी शब्द तयार होईल?
- (1) चौथे, दुसरे (2) तिसरे, दुसरे  
(3) पहिले, पाचवे (4) दुसरे, चौथे
29. दिलेल्या इंग्रजी अक्षरमालेतील उजवीकडून आठव्या अक्षराच्या डावीकडील सातवे अक्षर कोणते?
- (1) K (2) O (3) M (4) A

कच्च्या कामासाठी फक्त

A	B	C	D	E	F	G	H	I	J	K	L	M	N	O	P	Q	R	S	T	U	V	W	X	Y
---	---	---	---	---	---	---	---	---	---	---	---	---	---	---	---	---	---	---	---	---	---	---	---	---

30. In the given alphabet series which of the following pair of alphabet is at the same distance from the alphabet which is at the Ninth position from the left of the series? (Select two correct alternatives.)
- (1) FL                      (2) BN                      (3) BL                      (4) OC

Q. 31 to 35 Choose the odd term

31. (1) Divine                      (2) Deity                      (3) God                      (4) Ghost

32. (1) Loose motion                      (2) Malaria                      (3) Cholera                      (4) Dysentery

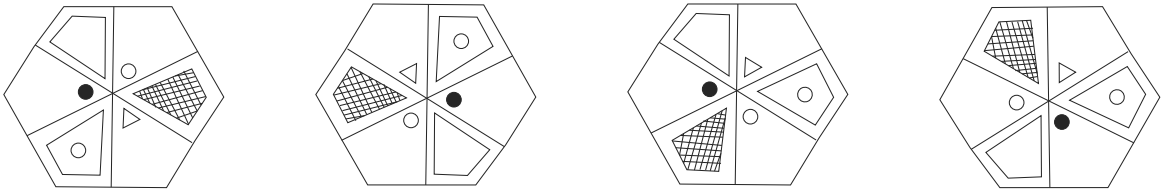
33. 
- (1)                      (2)                      (3)                      (4)

34. (1) 210                      (2) 336                      (3) 150                      (4) 504

35. (1) CH                      (2) EJ                      (3) LB                      (4) FD

Q. 36 to 40 Direction : -

In each of the following questions relation between 3rd and 4th term is similar to that as between 1st and 2nd term. Find the term to replace the question mark from the given alternatives.

36. Cause : Reason :: Perfect : ?
- (1) Pure                      (2) Imperfect                      (3) Idle                      (4) Ideal

SPACE FOR ROUGH WORK

A	B	C	D	E	F	G	H	I	J	K	L	M	N	O	P	Q	R	S	T	U	V	W	X	Y
---	---	---	---	---	---	---	---	---	---	---	---	---	---	---	---	---	---	---	---	---	---	---	---	---

30. दिलेल्या इंग्रजी अक्षरमालेतील नवव्या अक्षरापासून समान अंतरावरील अक्षरांची जोडी कोणती? (अचूक उत्तराचे दोन पर्याय निवडा.)
- (1) FL (2) BN (3) BL (4) OC

प्र. क्र. 31 ते 35 साठी सूचना - गटात न बसणारे पद ओळखा.

31. (1) यशोधन (2) मनोराज्य (3) तपोबल (4) चंद्रोदय
32. (1) जुलाब (2) हिक्ताप (3) कॉलरा (4) हगवण

33.

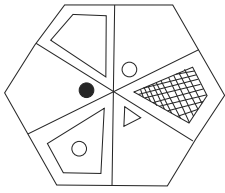

(1)

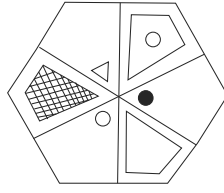

(2)

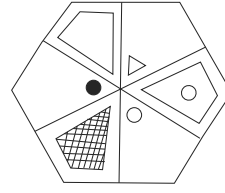

(3)

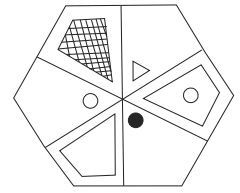

(4)

34. (1) 210 (2) 336 (3) 150 (4) 504
35. (1) CH (2) EJ (3) LB (4) FD

प्र. क्र. 36 ते 40 साठी सूचना -

समसंबंध ओळखून प्रश्नचिन्हाच्या जागीचा योग्य पर्याय निवडा.

36. हेम : कनक :: कटक : ?

- (1) तुकडा (2) तांबे (3) शहर (4) सैन्य

कच्च्या कामासाठी फक्त



A	B	C	D	E	F	G	H	I	J	K	L	M	N	O	P	Q	R	S	T	U	V	W	X	Y
---	---	---	---	---	---	---	---	---	---	---	---	---	---	---	---	---	---	---	---	---	---	---	---	---

37.

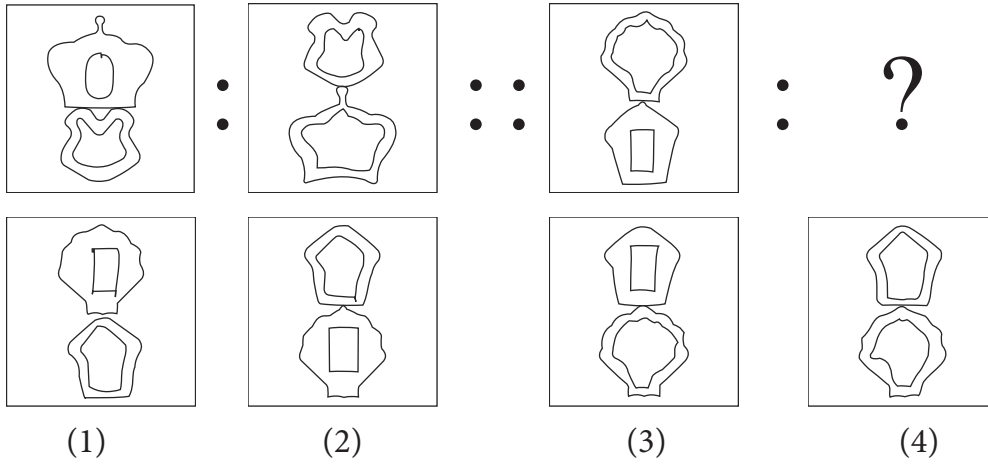

(1)

(2)

(3)

(4)

38. 69 : 123 :: 48 : ? (Select two correct alternatives)

(1) 112

(2) 102

(3) 80

(4) 84

39. 394 : 54 :: 875 : ?

(1) 55

(2) 94

(3) 140

(4) 146

40. ADJ : BFM :: CIO : ?

(1) DKR

(2) ELR

(3) DKQ

(4) DJP

**Q. 41 to 45 Direction :-**

In the following series, determine the rule underlying the series and find out the term to replace the question mark.

41. 812, 715, 626, 543, 464, 391, ?

(1) 316

(2) 320

(3) 318

(4) 309

SPACE FOR ROUGH WORK

37.

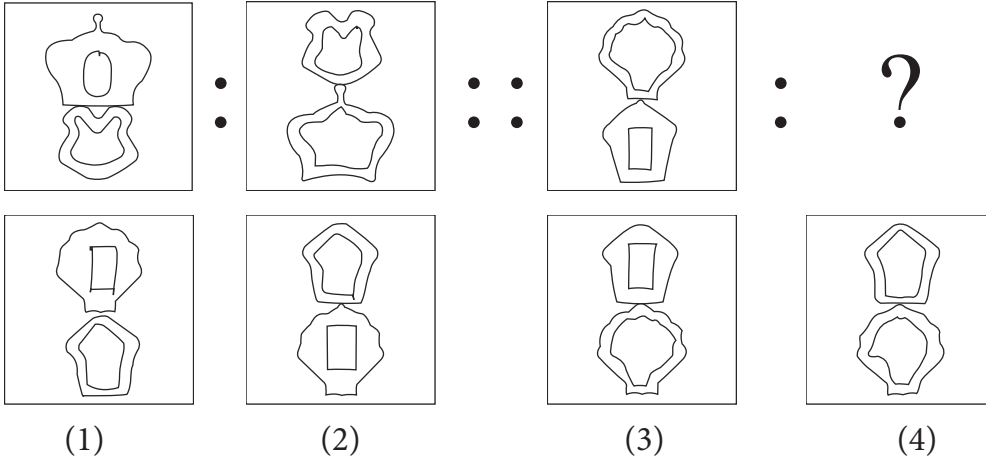

38. 69 : 123 :: 48 : ? (अचूक उत्तराचे दोन पर्याय निवडा)

- (1) 112 (2) 102 (3) 80 (4) 84

39. 394 : 54 :: 875 : ?

- (1) 55 (2) 94 (3) 140 (4) 146

40. ADJ : BFM :: CIO : ?

- (1) DKR (2) ELR (3) DKQ (4) DJP

प्र. क्र. 41 ते 45 साठी सूचना -

मालिकेतील प्रश्नचिन्हाच्या जागी येणारा योग्य पर्याय निवडा.

41. 812, 715, 626, 543, 464, 391, ?

- (1) 316 (2) 320 (3) 318 (4) 309

कच्च्या कामासाठी फक्त



A	B	C	D	E	F	G	H	I	J	K	L	M	N	O	P	Q	R	S	T	U	V	W	X	Y
---	---	---	---	---	---	---	---	---	---	---	---	---	---	---	---	---	---	---	---	---	---	---	---	---

42.

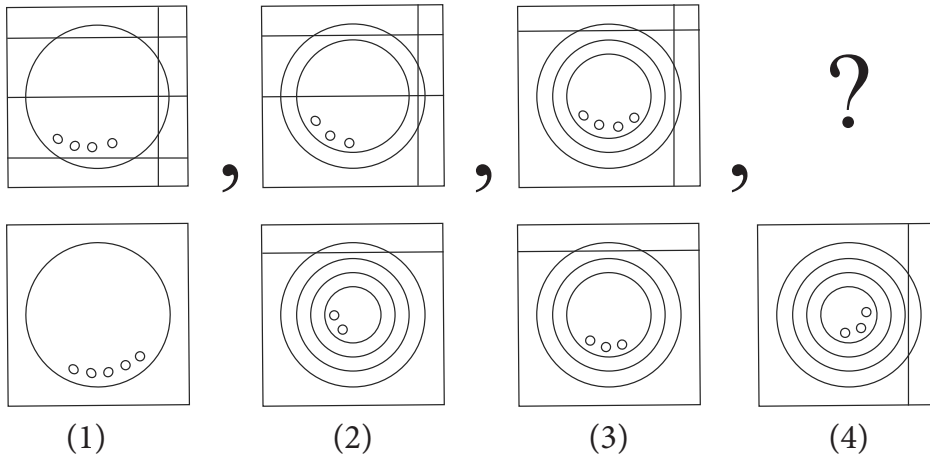

43.

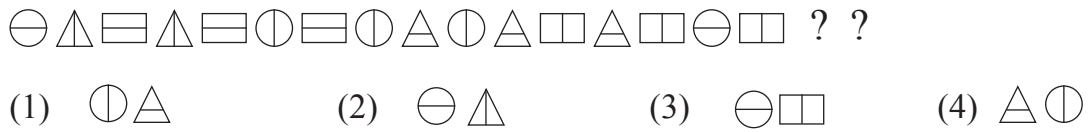

44.



45.



46.

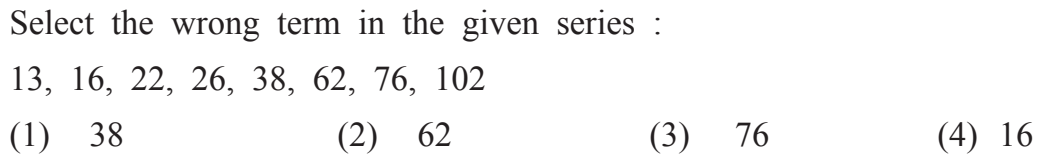

SPACE FOR ROUGH WORK

42.

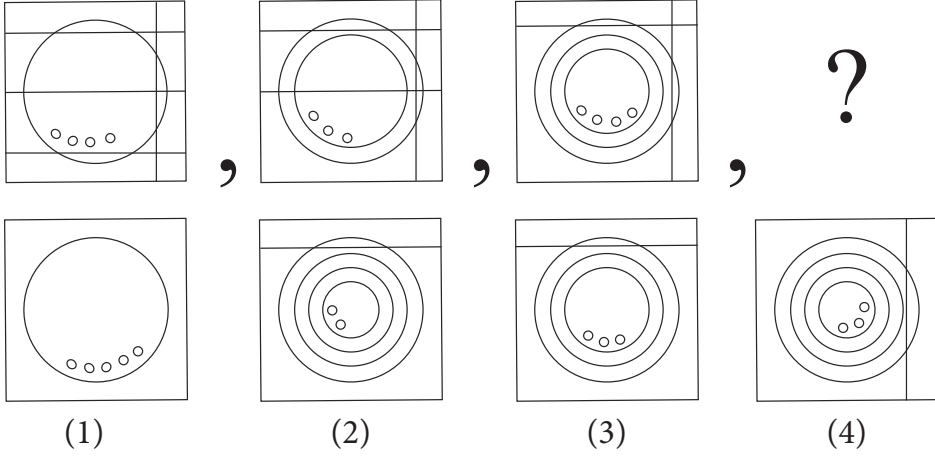

43.



- (1)  $\bigcirc \triangle$  (2)  $\ominus \triangle$  (3)  $\ominus \square$  (4)  $\triangle \bigcirc$

44.

BC, EG, HK, KO, NS, ?

- (1) NR (2) QK (3) EG (4) QW

45.

YXW, XVT, WSP, VOK, ?

- (1) UJE (2) UJF (3) YKE (4) XKE

46.

खाली दिलेल्या मालिकेतील चुकीचे पद ओळखा.

13, 16, 22, 26, 38, 62, 76, 102

- (1) 38 (2) 62 (3) 76 (4) 16

कच्च्या कामासाठी फक्त



A	B	C	D	E	F	G	H	I	J	K	L	M	N	O	P	Q	R	S	T	U	V	W	X	Y
---	---	---	---	---	---	---	---	---	---	---	---	---	---	---	---	---	---	---	---	---	---	---	---	---

47. Find the hidden part of the question figure from the given alternatives.

Question Fig.

Answer Fig.

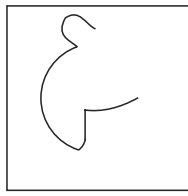
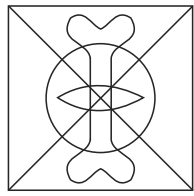

(1)

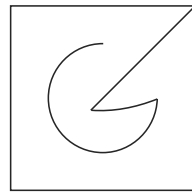

(2)

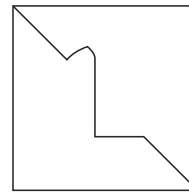

(3)

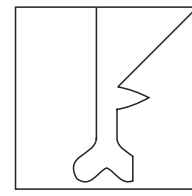

(4)

48. Choose the figure from the given alternatives that exactly matches the question figure.

Question Fig.

Answer Fig.

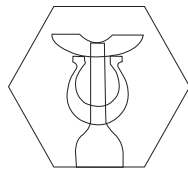
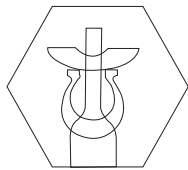

(1)

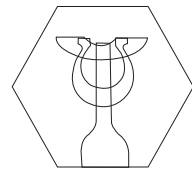

(2)

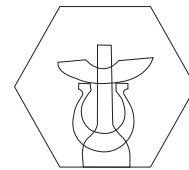

(3)

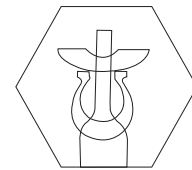

(4)

49. Choose the correct alternative to complete the question figure :

Question Fig.

Answer Fig.

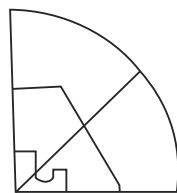
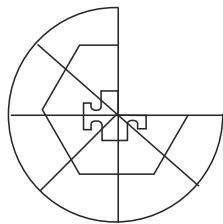

(1)

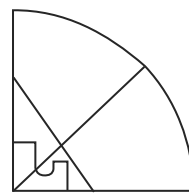

(2)

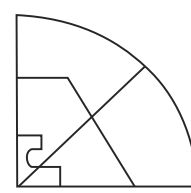

(3)

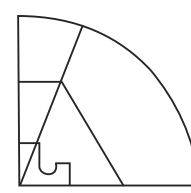

(4)

SPACE FOR ROUGH WORK



47. प्रश्नाकृतीचा लपलेला भाग असणारा पर्याय निवडा.

प्रश्नाकृती

उत्तराकृती

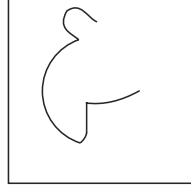
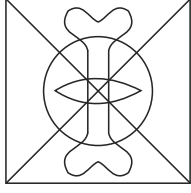

(1)

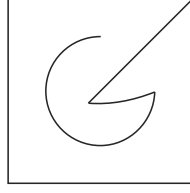

(2)

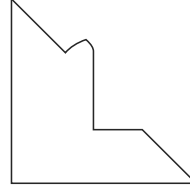

(3)

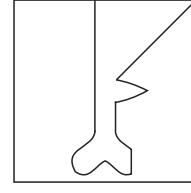

(4)

48. प्रश्नाकृतीसारखी तंतोतंत असणारी आकृती पर्यायांतून निवडा:

प्रश्नाकृती

उत्तराकृती

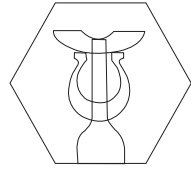
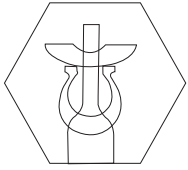

(1)

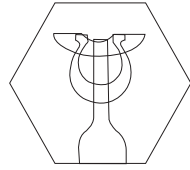

(2)

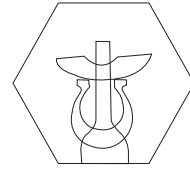

(3)

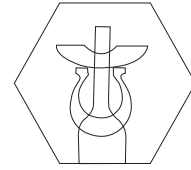

(4)

49. अपूर्ण आकृती पूर्ण करण्यासाठी योग्य पर्यायाची निवड करा.

प्रश्नाकृती

उत्तराकृती

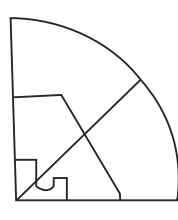
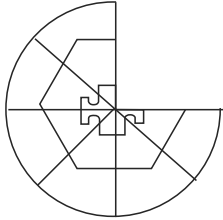

(1)

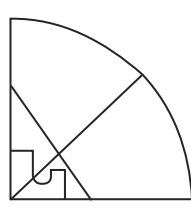

(2)

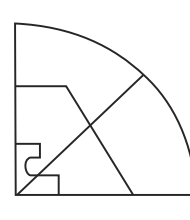

(3)

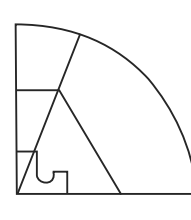

(4)

कच्च्या कामासाठी फक्त

50. Observe the numbers in the grid and choose the correct alternative to replace the question mark.

7	6	8
28	4	?
12	2	15

- (1) 34                      (2) 60                      (3) 17                      (4) 40

**Q. 51 and 52 Direction :**

A square sheet of paper is folded and cut as shown in the question figure. How will the figure look like when the paper is unfolded. Choose the correct alternative.

51. Question Fig.

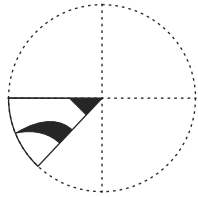

Answer Fig.

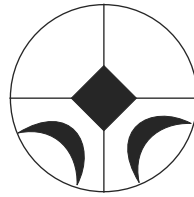

(1)

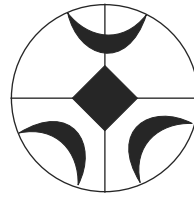

(2)

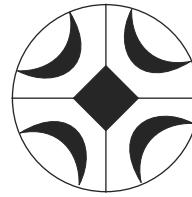

(3)

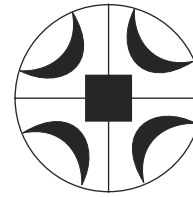

(4)

52. Question Fig.

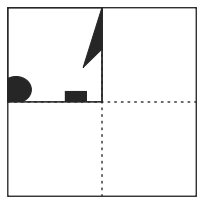

Answer Fig.

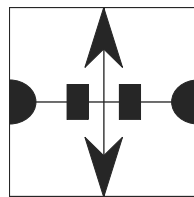

(1)

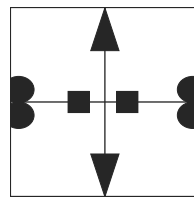

(2)

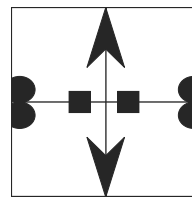

(3)

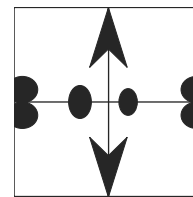

(4)

SPACE FOR ROUGH WORK

50. प्रश्नचिन्हाच्या जागीचा पर्याय निवडा:

7	6	8
28	4	?
12	2	15

(1) 34

(2) 60

(3) 17

(4) 40

प्र. क्र. 51 व 52 साठी सूचना -

घडीची आकृती उघडल्यावर पर्यायातील कोणत्या आकृतीप्रमाणे दिसेल?

51. प्रश्नाकृती

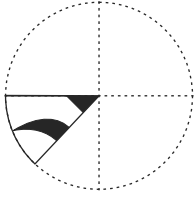

उत्तराकृती

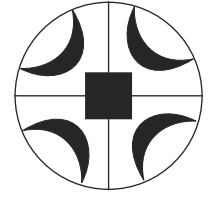
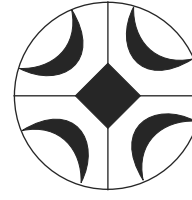
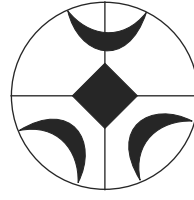
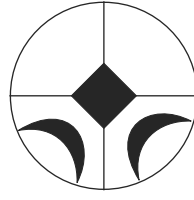

(1)

(2)

(3)

(4)

52. प्रश्नाकृती

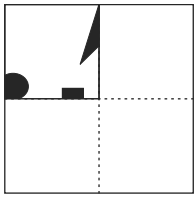

उत्तराकृती

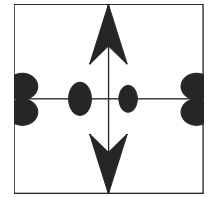
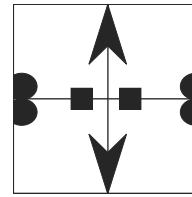
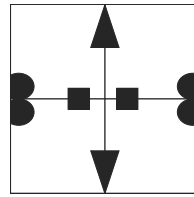
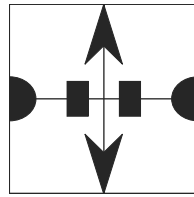

(1)

(2)

(3)

(4)

कच्च्या कामासाठी फक्त

**Q. 53 and 54 Direction :**

In the given Venn diagram numbers in circle represent farmers, numbers in triangle represent teachers and numbers in rectangle represent doctors.

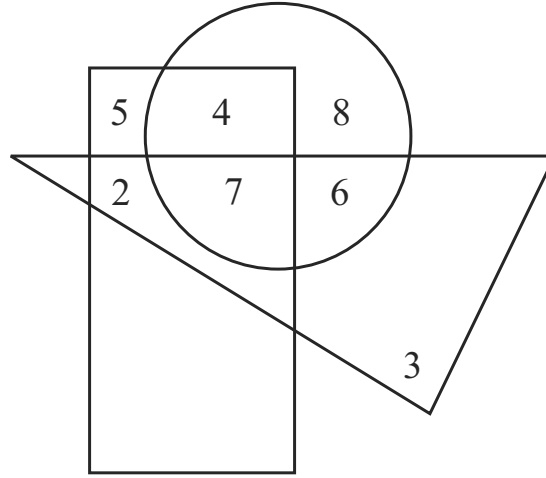

53. How many teachers are farmers also?  
 (1) 6                                      (2) 13                                      (3) 24                                      (4) 17
54. By how much is the number of doctors who are doing only farming is more or less than the number of teachers who are only doctors?  
 (1) more by four                                      (2) less by four  
 (3) more by two                                      (4) less by two
55. If Maharashtra Day occurs on Wednesday then which of the following day will occur five times in the month of September in the same year? (Select two correct alternatives)  
 (1) Sunday                                      (2) Saturday                                      (3) Tuesday                                      (4) Monday

**SPACE FOR ROUGH WORK**

प्र. क्र. 53 व 54 साठी सूचना -

पुढील वेनाकृतीतील वर्तुळात शेतकऱ्यांची, त्रिकोणात शिक्षकांची आणि आयतात डॉक्टरांची संख्या दाखवली आहे.

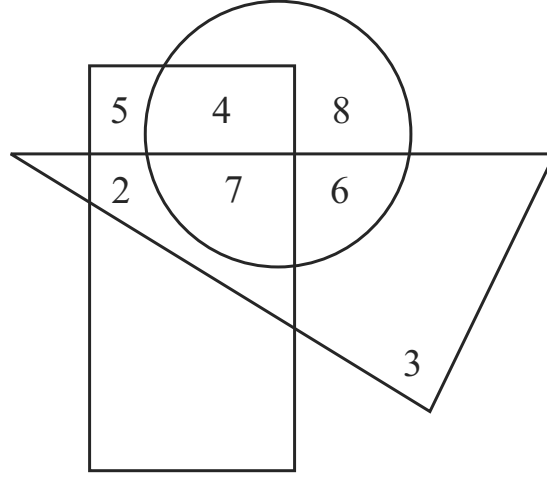

53. शेतकरी असलेल्या शिक्षकांची एकूण संख्या किती आहे?  
 (1) 6 (2) 13 (3) 24 (4) 17
54. फक्त शेती करणाऱ्या डॉक्टरांची संख्या, फक्त डॉक्टर असणाऱ्या शिक्षकांपेक्षा कितीने कमी अथवा जास्त आहे?  
 (1) चार ने जास्त (2) चार ने कमी  
 (3) दोन ने जास्त (4) दोन ने कमी
55. जर महाराष्ट्रदिन बुधवारी आला असेल तर सप्टेंबर महिन्यात कोणता वार पाच वेळा येईल?  
 (अचूक उत्तराचे दोन पर्याय निवडा.)  
 (1) रविवार (2) शनिवार (3) मंगळवार (4) सोमवार

कच्च्या कामासाठी फक्त

A	B	C	D	E	F	G	H	I	J	K	L	M	N	O	P	Q	R	S	T	U	V	W	X	Y
---	---	---	---	---	---	---	---	---	---	---	---	---	---	---	---	---	---	---	---	---	---	---	---	---

56. Abhishek is watching the sunset, he turns three times at right angle to his right, then which direction is indicated by his left hand?  
 (1) South                      (2) East                      (3) West                      (4) North

57. Akshay is standing at the 19th position which is middle of the row. If last eight students leave the row then what is the position of Prasanna from back of the row who is at the ninth position from the front of the row?  
 (1) 20                      (2) 19                      (3) 29                      (4) 21

58. Find the pattern of the numbers in the given arrangement and choose the correct alternative to replace the question mark.

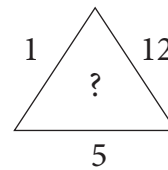
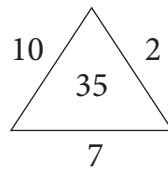
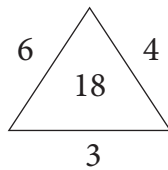
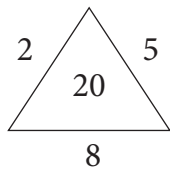

- (1) 15                      (2) 30                      (3) 24                      (4) 27

59. Find the total number of triangles in the given figure?

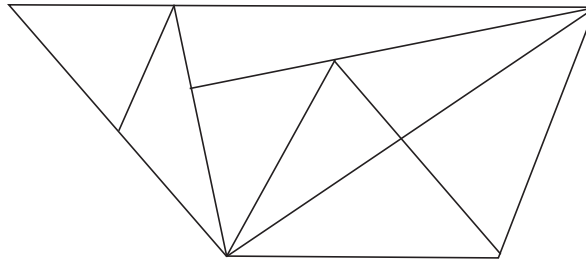

- (1) 15                      (2) 16                      (3) 17                      (4) 14

**SPACE FOR ROUGH WORK**

A	B	C	D	E	F	G	H	I	J	K	L	M	N	O	P	Q	R	S	T	U	V	W	X	Y
---	---	---	---	---	---	---	---	---	---	---	---	---	---	---	---	---	---	---	---	---	---	---	---	---

56. अभिषेक सूर्यास्त पाहात होता, तो तीन वेळा काटकोनातून उजवीकडे वळला, तर त्याच्या डाव्या हाताकडील दिशा कोणती?  
 (1) दक्षिण (2) पूर्व (3) पश्चिम (4) उत्तर

57. रांगेत मध्यभागी 19 व्या क्रमांकावर अक्षय उभा आहे, जर रांगेतील शेवटचे आठ विद्यार्थी निघून गेले, तर सुरुवातीपासून नवव्या क्रमांकावरील प्रसन्नचा शेवटून कितवा क्रमांक असेल?  
 (1) 20 (2) 19 (3) 29 (4) 21

58. संख्यांच्या मांडणीतील सूत्र ओळखून प्रश्नचिन्हाच्या जागीचा पर्याय निवडा.

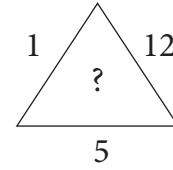
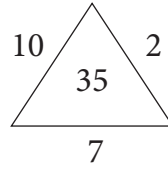
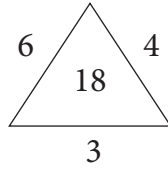
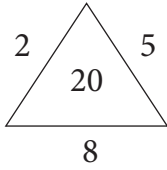

(1) 15 (2) 30 (3) 24 (4) 27

59. आकृतीत एकूण किती त्रिकोण आहेत?

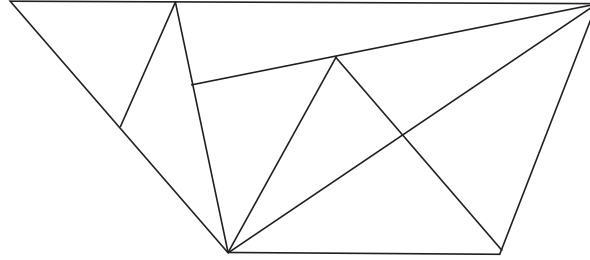

(1) 15 (2) 16 (3) 17 (4) 14

कच्च्या कामासाठी फक्त



A	B	C	D	E	F	G	H	I	J	K	L	M	N	O	P	Q	R	S	T	U	V	W	X	Y
---	---	---	---	---	---	---	---	---	---	---	---	---	---	---	---	---	---	---	---	---	---	---	---	---

60. What is the total number of cubes in the given question figure.

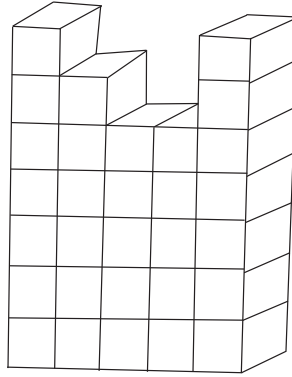

- (1) 35                      (2) 29                      (3) 28                      (4) 30

61. The ratio of ages of A, B, C is 5:7:12. If age of 'B' is more by two and a half years than age of 'A', then what was the age of 'C' two years before?

- (1) 13 years              (2) 10 years              (3) 12 years              (4) 15 years

62. In the clock, at what time the angle between hour hand and minute hand measures  $75^\circ$  ? (Select two correct alternatives)

- (1) 30 minutes past nine                      (2) 30 minutes past two  
(3) 30 minutes past three                      (4) 30 minutes past eight

63. Choose the mirror image of the question figure from the given alternatives.

Question Fig.

Answer Fig.

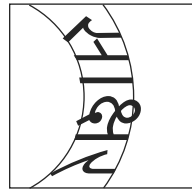
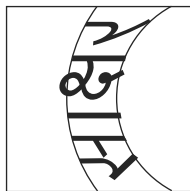

(1)

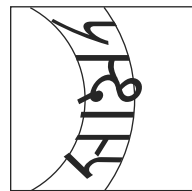

(2)

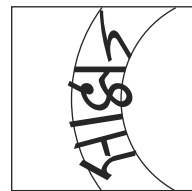

(3)

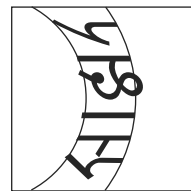

(4)

SPACE FOR ROUGH WORK



60. शेजारच्या आकृतीतील एकूण घनांची संख्या किती?

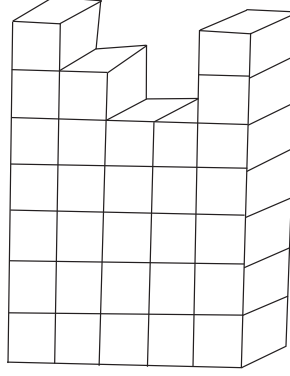

- (1) 35                      (2) 29                      (3) 28                      (4) 30

61. अ, ब, क या तीन भावांच्या वयांचे गुणोत्तर 5:7:12 असून 'अ' पेक्षा 'ब' चे वय अडीच वर्षांनी जास्त असेल, तर 'क' चे वय दोन वर्षांपूर्वी किती होते?

- (1) 13 वर्षे                      (2) 10 वर्षे                      (3) 12 वर्षे                      (4) 15 वर्षे

62. घड्याळ्याच्या तास व मिनिट काट्यात किती वाजता  $75^\circ$  मापाचा कोन होतो? (दोन अचूक पर्याय निवडा.)

- (1) 9 वा. 30 मि.                      (2) 2 वा. 30 मि.  
(3) 3 वा. 30 मि.                      (4) 8 वा. 30 मि.

63. प्रश्नाकृतीची आरशातील प्रतिमा पर्यायांतून निवडा.

प्रश्नाकृती

उत्तराकृती

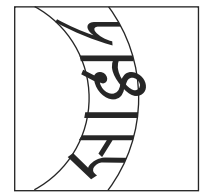
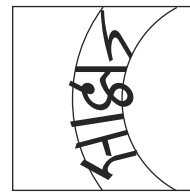
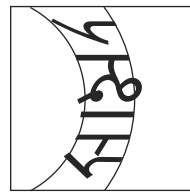
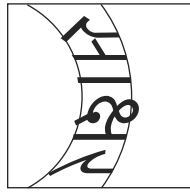
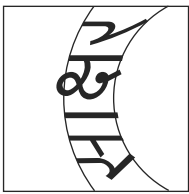

(1)

(2)

(3)

(4)

कच्च्या कामासाठी फक्त



A	B	C	D	E	F	G	H	I	J	K	L	M	N	O	P	Q	R	S	T	U	V	W	X	Y
---	---	---	---	---	---	---	---	---	---	---	---	---	---	---	---	---	---	---	---	---	---	---	---	---

**Q. 64 and 65 Direction:-**

Choose the water image of the question figure from the given alternatives.

64. Question Fig.

Answer Fig.

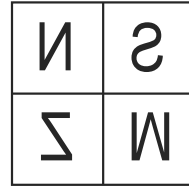
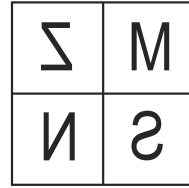
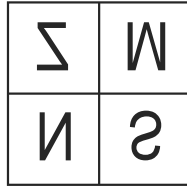
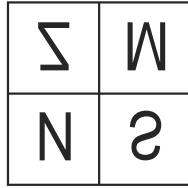
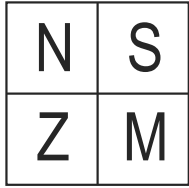

(1)

(2)

(3)

(4)

65. Question Fig.

Answer Fig.

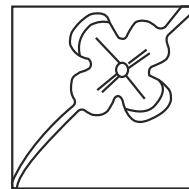
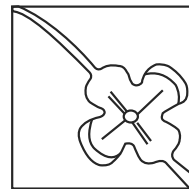
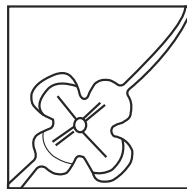
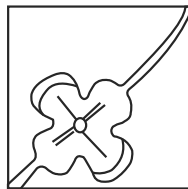
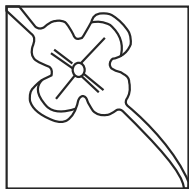

(1)

(2)

(3)

(4)

SPACE FOR ROUGH WORK

प्र. क्र. 64 व 65 साठी सूचना -

प्रश्नाकृतीचे जलप्रतिबिंब पर्यायांतून निवडा.

64. प्रश्नाकृती

उत्तराकृती

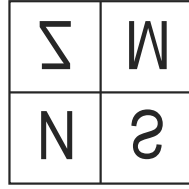
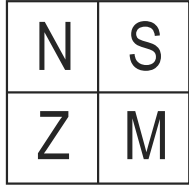

(1)

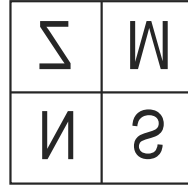

(2)

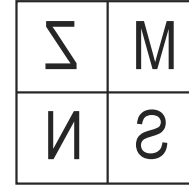

(3)

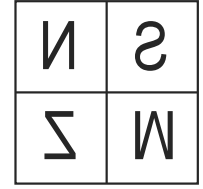

(4)

65. प्रश्नाकृती

उत्तराकृती

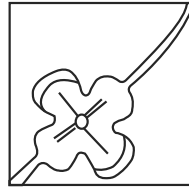
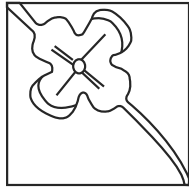

(1)

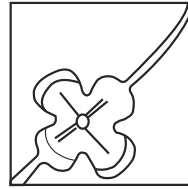

(2)

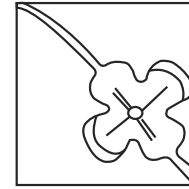

(3)

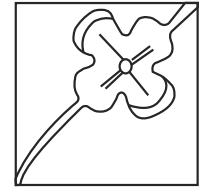

(4)

कच्च्या कामासाठी फक्त

A	B	C	D	E	F	G	H	I	J	K	L	M	N	O	P	Q	R	S	T	U	V	W	X	Y
---	---	---	---	---	---	---	---	---	---	---	---	---	---	---	---	---	---	---	---	---	---	---	---	---

**Q. 66 to 68 Direction : -**

Observe the following pyramid of numbers and the sequence of terms given in the questions that follow. Choose the correct term from the given alternatives to replace the question mark.

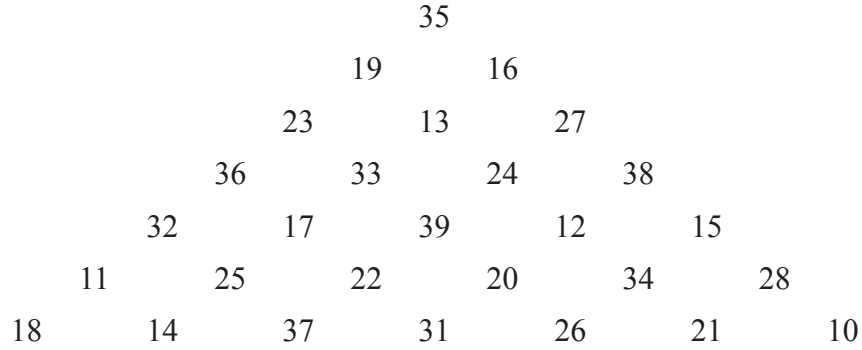

66. 11, 17, 31 : 37, 22, 32 :: 28, 12, 31 : ?  
 (1) 21, 34, 38      (2) 26, 20, 38      (3) 26, 20, 15      (4) 26, 34, 15
67. 23, 33, 17 : 12, 24, 27 :: 32, 25, 14 : ? (Choose two correct alternatives)  
 (1) 26, 20, 38      (2) 31, 22, 39      (3) 34, 12, 27      (4) 21, 34, 15
68. 18, 32, 14, 17, 37, ?, 31, 12  
 (1) 24                      (2) 27                      (3) 39                      (4) 38

**Q. 69 to 71 Direction : -**

Identify the rhythmic arrangement of terms given below and find the correct term to replace the question mark.

69. a b c d e b b c d e a c ? d e a ? d d e a b ? e e  
 (1) c b d                      (2) b b c                      (3) c c d                      (4) c b c

**SPACE FOR ROUGH WORK**



A	B	C	D	E	F	G	H	I	J	K	L	M	N	O	P	Q	R	S	T	U	V	W	X	Y
---	---	---	---	---	---	---	---	---	---	---	---	---	---	---	---	---	---	---	---	---	---	---	---	---

प्र. क्र. 66 ते 68 साठी सूचना -

दिलेल्या मनोच्याचा उपयोग करा.

				35							
				19		16					
			23		13		27				
			36		33		24		38		
		32		17		39		12	15		
	11		25		22		20		34	28	
18		14		37		31		26		21	10

66. 11, 17, 31 : 37, 22, 32 :: 28, 12, 31 : ?  
(1) 21, 34, 38 (2) 26, 20, 38 (3) 26, 20, 15 (4) 26, 34, 15

67. 23, 33, 17 : 12, 24, 27 :: 32, 25, 14 : ? (दोन अचूक पर्याय निवडा.)  
(1) 26, 20, 38 (2) 31, 22, 39 (3) 34, 12, 27 (4) 21, 34, 15

68. 18, 32, 14, 17, 37, ?, 31, 12  
(1) 24 (2) 27 (3) 39 (4) 38

प्र. क्र. 69 ते 71 साठी सूचना -

मालिकेतील लयबद्ध मांडणीतील प्रश्नचिन्हांच्या जागी येणाऱ्या पदांचा पर्याय निवडा.

69. a b c d e b b c d e a c ? d e a ? d d e a b ? e e  
(1) c b d (2) b b c (3) c c d (4) c b c

कच्च्या कामासाठी फक्त

A	B	C	D	E	F	G	H	I	J	K	L	M	N	O	P	Q	R	S	T	U	V	W	X	Y
---	---	---	---	---	---	---	---	---	---	---	---	---	---	---	---	---	---	---	---	---	---	---	---	---

70.  $\bigcirc + \triangle \times \square \times \square \bigcirc + \triangle ? \triangle \times ? \bigcirc \square \bigcirc + ? \times \triangle \times \square \bigcirc +$   
 (1)  $+\square\triangle$  (2)  $+\triangle\triangle$  (3)  $\times\square\triangle$  (4)  $+\square\bigcirc$

71. 0 1 2 1 2 3 2 3 4 3 4 5 4 ? ? ? ? 7 6 7 8 7 8 9  
 (1) 5 6 4 5 (2) 4 5 6 4 (3) 5 6 5 6 (4) 5 6 7 5

**Q. 72 to 74 Direction -**

In a certain code language MAT is written as '427', CAN is written as '584' and NOT is written as '597'. The relation of letters and numbers may not be one to one.

72. Which number represents alphabet 'C'?

- (1) 4 (2) 5 (3) 8 (4) 2

73. What is the code for 'EAT'?

- (1) 547 (2) 247 (3) 289 (4) 147

74.  $M + C - T = ?$

- (1) 5 (2) 3 (3) 2 (4) 8

75. Observe the numbers given in the grid and choose the correct alternative to replace the question mark. (Select two correct alternatives)

73	?	61
59	43	71
47	67	53

- (1) 37 (2) 41 (3) 79 (4) 77

**SPACE FOR ROUGH WORK**



A	B	C	D	E	F	G	H	I	J	K	L	M	N	O	P	Q	R	S	T	U	V	W	X	Y
---	---	---	---	---	---	---	---	---	---	---	---	---	---	---	---	---	---	---	---	---	---	---	---	---

70.  $\bigcirc + \triangle \times \square \times \square \bigcirc + \triangle ? \triangle \times ? \bigcirc \square \bigcirc + ? \times \triangle \times \square \bigcirc +$   
(1)  $+\square\triangle$  (2)  $+\triangle\triangle$  (3)  $\times\square\triangle$  (4)  $+\square\bigcirc$

71. 0 1 2 1 2 3 2 3 4 3 4 5 4 ? ? ? ? 7 6 7 8 7 8 9  
(1) 5 6 4 5 (2) 4 5 6 4 (3) 5 6 5 6 (4) 5 6 7 5

प्र. क्र. 72 ते 74 साठी सूचना -

एका सांकेतिक भाषेत 'सलग' हा शब्द '427' असा, 'लपव' हा शब्द '584' असा आणि 'गवत' हा शब्द '597' असा लिहितात, तर .....

72. 'ल' साठी कोणता अंक वापरला आहे?

(1) 2 (2) 5 (3) 4 (4) 7

73. याच सांकेतिक भाषेत 'बारा वर्षांचा काळ' या शब्दसमूहाबद्दल येणाऱ्या दोन अक्षरी शब्दांचे सांकेतिक रूप कोणते?

(1) 48 (2) 59 (3) 52 (4) 98

74.  $ग + प \times स =$  किती?

(1) 17 (2) 23 (3) 47 (4) 34

75. संख्यांच्या मांडणीतील सूत्र ओळखून प्रश्नचिन्हाच्या जागीचा पर्याय निवडा. (दोन अचूक उत्तराचे पर्याय निवडा.)

73	?	61
59	43	71
47	67	53

(1) 37 (2) 41 (3) 79 (4) 77

कच्च्या कामासाठी फक्त

SPACE FOR ROUGH WORK