

पूर्व उच्च प्राथमिक शिष्यवृत्ती परीक्षा (इयत्ता 5वी), फेब्रुवारी 2018

बैठक क्र.

--	--	--	--	--	--	--	--	--	--

0 1 0 2

संच

A

प्रश्नपत्रिका क्र. II

माध्यम : मराठी

वेळ : 1.30 ते 3.00

पृष्ठ : 32

तृतीय भाषा व बुद्धिमत्ता चाचणी

एकूण गुण : 150

प्रश्नपत्रिका सोडविण्यापूर्वी कृपया खालील सूचना काळजीपूर्वक वाचा :

- (1) या प्रश्नपत्रिकेत दोन विभाग आहेत. त्यापैकी विभाग I मध्ये तृतीय भाषा विषयासाठी 1 ते 25 व विभाग II मध्ये बुद्धिमत्ता चाचणी विषयासाठी 26 ते 75 असे एकूण 75 प्रश्न आहेत. सर्व प्रश्न सोडविणे आवश्यक आहे.
- (2) प्रत्येक प्रश्नासाठी 2 गुण आहेत.
- (3) प्रश्नपत्रिका सोडविण्यासाठी एकूण 90 मिनिटांचा कालावधी दिला जाईल.
- (4) उत्तरे नोंदविण्यासाठी स्वतंत्र उत्तरपत्रिका दिलेली आहे. प्रत्येक प्रश्नक्रमांकासमोर चार पर्यायासाठी क्रमागत वर्तुळे दिलेली आहेत. त्यातील अचूक उत्तराचा पर्याय क्रमांक असलेले वर्तुळ पुढील उदाहरणात दाखविल्याप्रमाणे रंगवा.
उदा. प्रश्न क्र. 6 च्या बरोबर उत्तराचा पर्याय क्र. 2 असेल, तर तो पुढीलप्रमाणे नोंदवावा.
प्रश्न क्र. 6 ① ● ③ ④
- (5) खालीलप्रमाणे नोंदविलेली उत्तरे ग्राह्य धरण्यात येणार नाहीत. असे उत्तर नोंदविल्यास त्या प्रश्नास 'शून्य' गुण दिले जातील.
① ② ● ④
- (6) पर्यायाची उत्तरे नोंदविताना फक्त काळ्या किंवा निळ्या रंगाच्या बॉलपेनचाच वापर करावा. पेन्सिलने नोंदविलेली उत्तरे ग्राह्य धरण्यात येणार नाहीत.
- (7) एकदा नोंदविलेली उत्तरे पुन्हा बदलता येणार नाहीत.
- (8) प्रत्येक प्रश्नासाठी एकापेक्षा अधिक वर्तुळात नोंदविलेली उत्तरे, खाडाखोड करून नोंदविलेली उत्तरे ग्राह्य धरण्यात येणार नाहीत.
- (9) प्रश्नपत्रिकेत प्रत्येक पानावर खाली व शेवटच्या पानावर कच्चे काम करण्यासाठी मोकळी जागा आहे, तेथेच कच्चे काम करावे.
- (10) परीक्षेस मर्यादित वेळ असल्याने एखाद्या प्रश्नाचे उत्तर तुम्हाला येत नसल्यास पुढील प्रश्न सोडवा. शेवटी वेळ शिल्लक राहिल्यास उरलेल्या प्रश्नांसाठी पुन्हा प्रयत्न करा.
- (11) एखाद्या प्रश्नात त्रुटी/चूक आढळल्यास त्याबाबत पर्यवेक्षक किंवा परीक्षा केंद्रसंचालक यांच्याकडे विचारणा करू नये.
- (12) प्रश्नातील त्रुटी/चूक/आक्षेपाबाबतचे निवेदन शाळेत किंवा पालकांनी गटशिक्षणाधिकारी किंवा शिक्षणाधिकारी यांच्याकडे लेखी स्वरूपात न पाठवता संबंधित शाळेच्या लॉगीन मधून ऑनलाईन पद्धतीनेच पाठवावे.
- (13) त्रुटी/चूक/आक्षेपाबाबतचे निवेदन ऑनलाईन पद्धतीने पाठविण्याची मुदत परीक्षा परिषदेच्या संकेतस्थळावर अंतरिम (तात्पुरती) उत्तरसूची प्रसिद्ध झाल्यापासून 10 (दहा) दिवसांपर्यंत राहिल.
- (14) मुद्रणदोष किंवा अन्य कारणांमुळे प्रश्न चुकीचा असल्याचे आढळल्यास तज्ञ समितीच्या अभिप्रायानुसार तो रद्द केला जाईल.
- (15) मुळ माध्यमासोबत इंग्रजी भाषेतील प्रश्नपत्रिका दिलेली आहे. मूळ माध्यमातील संदिग्ध प्रश्नांबाबत इंग्रजी प्रश्न पहावेत.

विभाग I

तृतीय भाषा

Instructions for Q. Nos. 1 to 3 : Read the passage carefully and answer the following questions.

The horse is a common tame animal. After the cow, buffalo and the goat; it is the most useful animal. A horse is used for riding, in hunting. It draws our carts. It is very faithful.

1. Select the correct option.

The horse is most _____ animal.

- (1) useless (2) harmful (3) careless (4) useful

2. Choose the animal which is not mentioned in the given passage.

- (1) cow (2) bullock (3) buffalo (4) goat

3. Select the correct alternative.

A horse is not used for _____

- (1) riding (2) drawing carts
(3) nothing (4) hunting

4. Select the mismatched pair.

- (1) actor – tractor (2) cricket – sachet
(3) tower – power (4) plastic – elastic

5. Observe the picture carefully and select the proper motto.

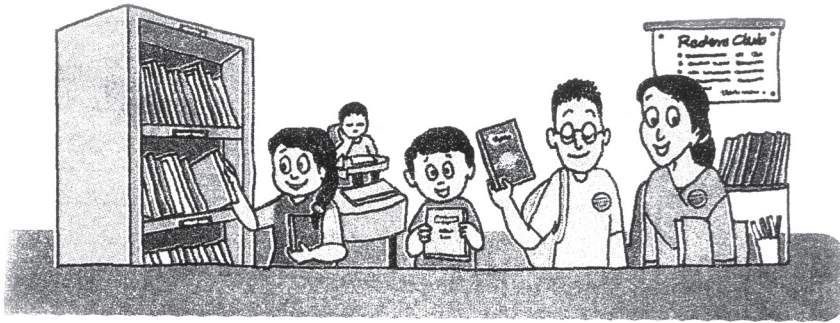

- (1) We love books (2) Protect all animals
(3) Health is wealth (4) Protect all plants

6. Arrange the numbers properly and make the meaningful word.

a	r	e	f	t	v	i	u	o
1	2	3	4	5	6	7	8	9

- (1) 41893762 (2) 416982753 (3) 213457698 (4) 541628739

7. The sign  indicates that one should _____.

- (1) go straight (2) turn left (3) up ward (4) turn right

8. Select the correct alternative.

We should cut our nails _____.

- (1) daily (2) early (3) carelessly (4) regularly

9. Choose the correct alternative.

Type of Plants



- (1) bud (2) root (3) stem (4) herb

10. Choose the correct option for making a request.

My friend Arnav forgot his eraser and wants to borrow it _____.

- (1) I brought your eraser. (2) Please, give me your eraser.
 (3) Can I give my eraser to you? (4) Find my eraser.

11. Complete the grid by choosing proper set of alphabets.

c									
r									
	s	t	r	i			h		
w					r				
					a				
					n				
						a	g	l	e

- (1) a, i, g (2) p, k, l (3) o, k, e (4) o, c, e

12. Choose the correct option for the given word.

shape

- (1) aroma (2) rough (3) brick (4) vapour

13. Select the correct punctuation mark that mentioned in the given sentence.

Well done Rahim!

- (1) Exclamation mark (2) Question mark
(3) Full stop (4) Comma

14. If pigs: squeal : then wolves : ?

- (1) howl (2) growl (3) squeak (4) croak

15. Observe the picture and choose the correct expression.



- (1) How sad! (2) What a surprise?
(3) How miserable! (4) What a pity!

16. Fill in the blank by using the correct article.

The cow is _____ useful animal.

- (1) an (2) a (3) the (4) no article.

17. Select the correct option.

Vedant and his team won the football match.

Their friends said, _____.

- (1) Congratulations! (2) Best of luck!
(3) Happy birthday! (4) Good bye!

18. Choose the correct sentence showing correct position of a comma (,).

- (1) I ordered potatoes, sugar, eggs, and coffee.
(2) I ordered, potatoes, sugar, eggs and coffee.
(3) I ordered potatoes, sugar, eggs and coffee.
(4) I ordered potatoes sugar eggs, and coffee.

19. Select the correct option.

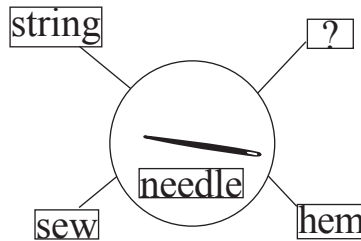

- (1) toss (2) spill (3) blink (4) stitch

20. Solve the riddle.

It has three blades. They go round and round.

It gives cool air. What is it?

- (1) a fan (2) a lamp (3) a refrigerator (4) an oven

21. Select the correct speech for the given picture.

- (1) What's wrong?
(2) I don't know.
(3) I can't hear you.
(4) I don't like it.



22. Select the suitable phrase for the given sentence.

_____ there lived a king.

- (1) Long long ago (2) Many years from now
(3) Day after tomorrow (4) Just now

23. Choose the correct punctuation mark for the given sentence.

Are you ready:

- (1) Full stop (2) Question mark (3) Comma (4) Apostrophe

24. Fill in the blanks with the correct option.

I wash my hands _____ and _____ eating.

- (1) near and close (2) up and down
(3) over and under (4) before and after

25. Select the proper alternative.

I brush my teeth _____ a day.

- (1) two (2) twice (3) too (4) first

विभाग II

बुद्धिमत्ता चाचणी

26. 'हीच मराठी जिच्या मुखाने वदली ज्ञानेश्वरी,
शिवबाने तलवार घासली याच मराठीवरी॥'
- या काव्यपंक्तीत ई-कारांत शब्दांपेक्षा अ-कारांत शब्द कितीने कमी अगर जास्त आहे?
- (1) 3 ने जास्त (2) 2 ने कमी
(3) 3 ने कमी (4) 2 ने जास्त

प्रश्न 27 ते 31: साठी सूचना- गटात न बसणारे पद ओळखा.

27. (1) 17 (2) 290 (3) 730 (4) 71
28. (1) 319 (2) 232 (3) 251 (4) 174
29. (1) सुरस नीरस (2) कोडकौतुक (3) न्यायनिवाडा (4) नवाकोरा

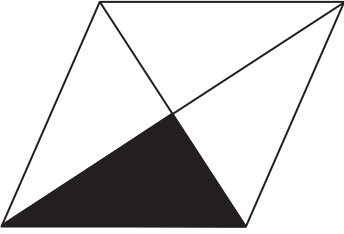
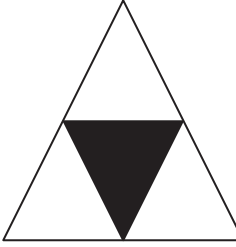
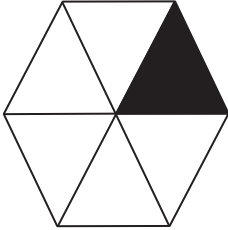
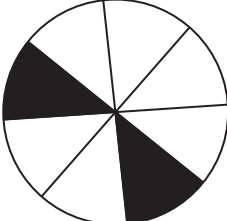
30. (1)  (2) 
- (3)  (4) 

कच्च्या कामासाठी जागा

Section II

Intelligence Test

26. "Merit consists in doing good to others, sin in doing harm to others." In this sentence how many words having five letters each are more or less than the words having two letters each?

- (1) more by 2 (2) less by 1 (3) less by 2 (4) more by 1

Instructions for Q. Nos. 27 to 31 : Find out the odd term.

27. (1) 17 (2) 290 (3) 730 (4) 71

28. (1) 319 (2) 232 (3) 251 (4) 174

29. (1) Preliminary (2) Prehistoric (3) Prepaid (4) Preposition

30. (1)

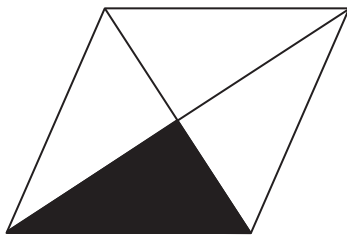

(2)

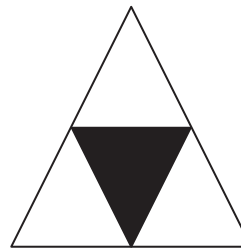

(3)

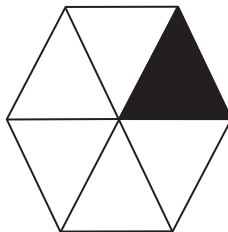

(4)

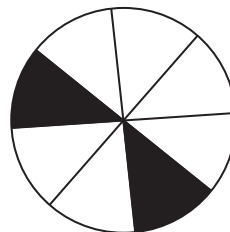

Space for Rough Work

31. (1)

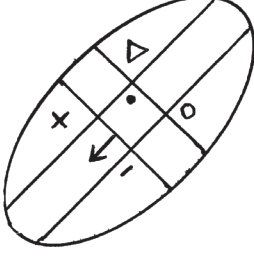

(2)

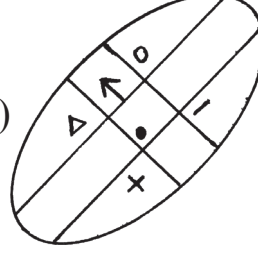

(3)

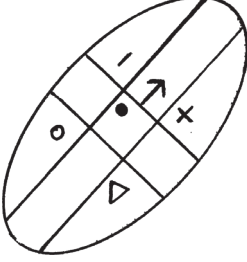

(4)

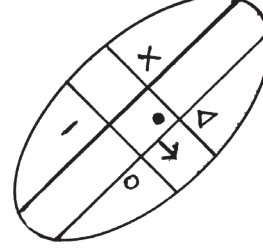

प्रश्न 32 व 33: साठी सूचना- खालील संख्यामालिकेत प्रश्नचिन्हाच्या जागी क्रमाने येणारी संख्या पर्यायांमधून निवडा.

32. 114, 85, 62, 43, ? 13

(1) 26

(2) 18

(3) 24

(4) 21

33. 11, 12, 16, 52, ? 92, 96

(1) 77

(2) 56

(3) 61

(4) 83

34. अमन ओबामाच्या उत्तरेस 10 मी. अंतरावर उभा असून रफिकच्या वायव्येस 20 मी. अंतरावर उभा आहे, तर रफिक ओबामाच्या कोणत्या दिशेस उभा आहे?

(1) पूर्व

(2) पश्चिम

(3) दक्षिण

(4) उत्तर

कच्च्या कामासाठी जागा

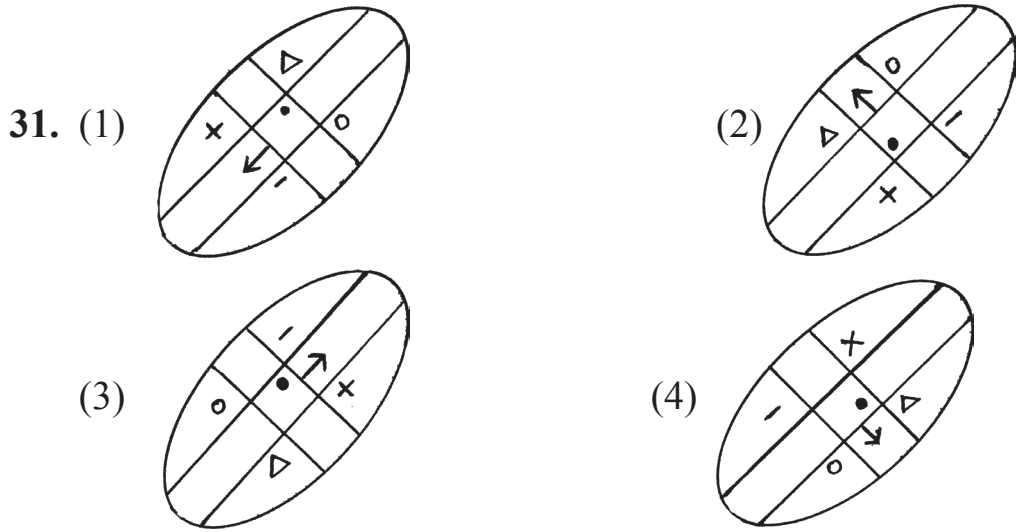

Instructions for Q. Nos. 32 to 33 :Observe the number series and find the correct alternative to replace the question mark. (?)

32. 114, 85, 62, 43, ? 13

- (1) 26 (2) 18 (3) 24 (4) 21

33. 11, 12, 16, 52, ? 92, 96

- (1) 77 (2) 56 (3) 61 (4) 83

34. Aman is standing 10 metres away from Obama facing North and 20 metres away from Rafiq facing NORTH-WEST, then in which direction is Rafiq standing to Obama?

- (1) East (2) West (3) North (4) South

Space for Rough Work

35. खालील पर्यायातील आकृत्यांच्या डाव्या बाजूस आरसा धरल्यास कोणती आकृती आरशात जशीच्या तशी दिसेल?

(1) HTH

(2) YNY

(3) IZI

(4) OSO

36. खालील प्रश्नाकृतीची आरशातील प्रतिमा कशी दिसेल ते पर्यायी उत्तर आकृत्यांमधून निश्चित करा.

प्रश्नाकृती

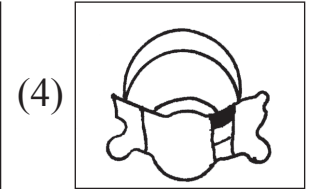
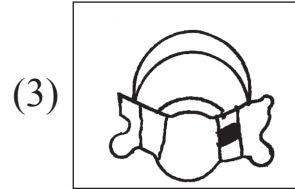
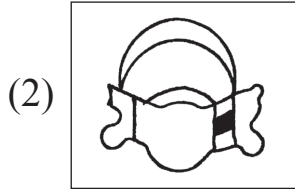
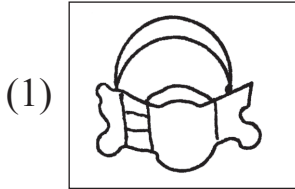
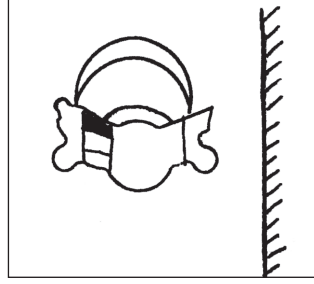

37. ऑगस्ट महिन्याच्या 6 तारखेस शुक्रवार असेल, तर त्याच महिन्यातील शेवटच्या बुधवारी किती तारीख असेल?

(1) 31

(2) 25

(3) 27

(4) 30

कच्च्या कामासाठी जागा

35. If the mirror is held from the left side of the given figures. which figure will look as it is?

(1) HTH

(2) YNY

(3) I Z I

(4) OSO

36. Find the correct figure from the alternatives which is the mirror image of the question figure.

Question Figure

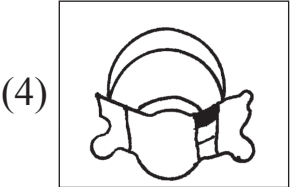
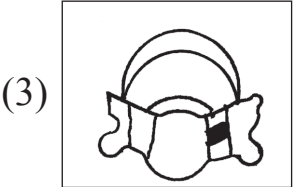
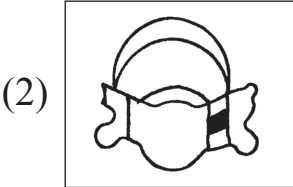
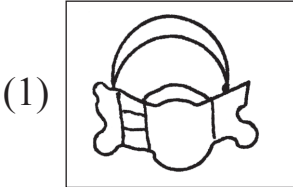
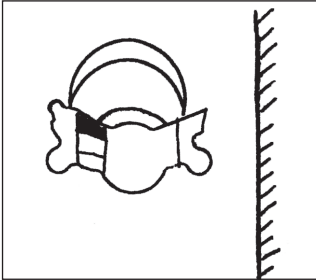

37. If 6th August was Friday, then in the same month what date it will be on last Wednesday?

(1) 31

(2) 25

(3) 27

(4) 30

Space for Rough Work

प्रश्न 38 व 39: साठी सूचना- खालील प्रश्नाकृतींचे पाण्यातील प्रतिबिंब कसे दिसेल ते पर्यायी उत्तर आकृत्यांमधून निश्चित करा.

38. प्रश्नाकृती

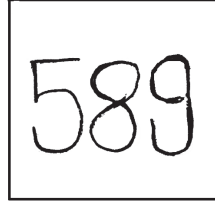

- (1) (2) (3) (4)

39. प्रश्नाकृती

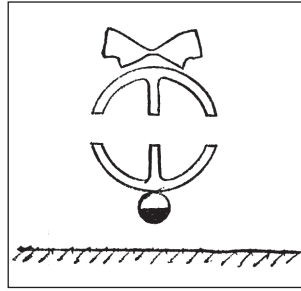

- (1) (2) (3) (4)

कच्च्या कामासाठी जागा

Instructions for Q. Nos. 38 to 39 : Select the correct figure that is water image of the question figure from the alternatives.

38. Question Figure

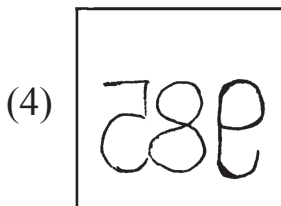
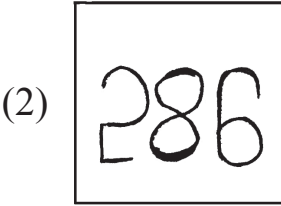
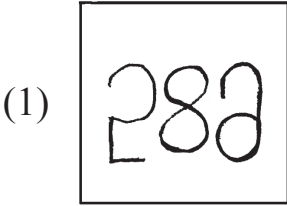

39. Question Figure

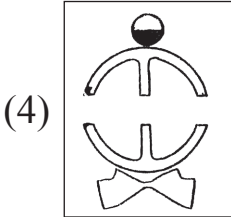
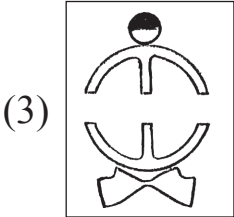
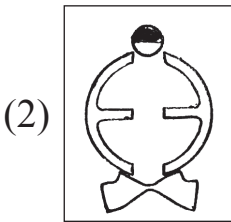
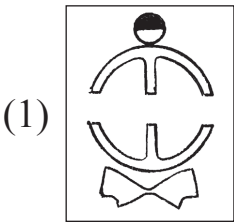
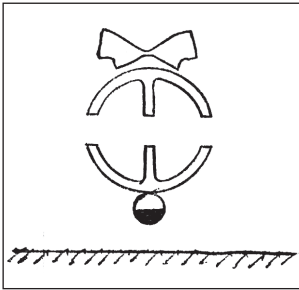

Space for Rough Work

अक्षरमाला : ABCDE FGHIJ KLMNO PQRST UVWXY

40. रेखाचा दुसरा वाढदिवस 25 जुलै 2009 रोजी शनिवारी होता, तर तिचा जन्म कोणत्या वारी झाला असावा?

- (1) सोमवार (2) मंगळवार
(3) बुधवार (4) गुरुवार

41. खालील अक्षरमालेत कोणती अक्षरे समानवेळा आली आहेत?

अक्षर माला: A B C D B A C A D C D A C D B C

- (1) A आणि D (2) D आणि C
(3) A आणि B (4) D आणि B

प्रश्न 42 ते 46: साठी सूचना- पुढील प्रश्नात पहिल्या व दुसऱ्या पदाचा जसा संबंध आहे, अगदी तसाच संबंध तिसऱ्या व चौथ्या पदात आहे. तो ओळखून प्रश्नचिन्हाच्या जागी येणारे पद पर्यायांतून निवडा.

42. गोवा : पणजी : : आसाम : ?

- (1) रांची (2) कोहिमा (3) दिसपूर (4) गंगटोक

43. 3564 : 6 :: 7827 : ?

- (1) 2 (2) 8 (3) 12 (4) 10

44. 36 : 10 :: 27 : ?

- (1) 26 (2) 16 (3) 15 (4) 24

कच्च्या कामासाठी जागा

Alphabets : A B C D E F G H I J K L M N O P Q R S T U V W X Y

40. Rekha's second birthday was on Saturday 25th July 2009, then on what day was she born?

- (1) Monday (2) Tuesday
(3) Wednesday (4) Thursday

41. In the given alphabetical series which letters are repeated same number of times?

Letters : A B C D B A C A D C D A C D B C

- (1) A and D (2) D and C
(3) A and B (4) D and B

Instructions for Q. Nos. 42 to 46 : There exists a certain relation between first and second term. The same relation exists between third and fourth term. Considering this choose the correct alternative to replace the question mark (?)

42. Goa : Panaji :: Aassam : ?

- (1) Ranchi (2) Kohima (3) Dispur (4) Gangtok

43. 3564 : 6 :: 7827 : ?

- (1) 2 (2) 8 (3) 12 (4) 10

44. 36 : 10 :: 27 : ?

- (1) 26 (2) 16 (3) 15 (4) 24

Space for Rough Work

45.

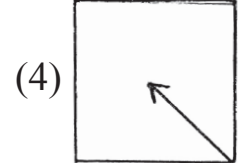
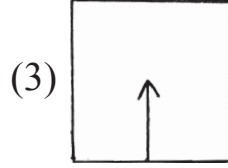
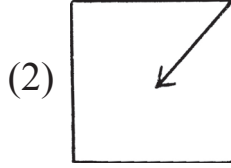
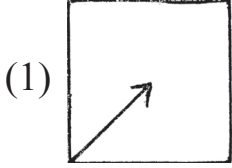
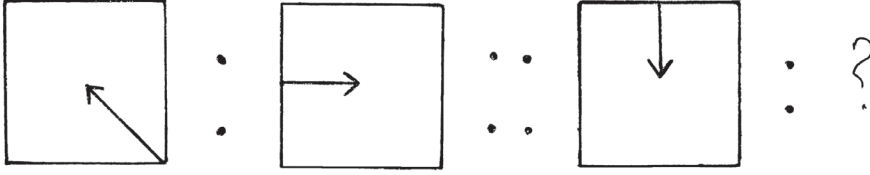

46.

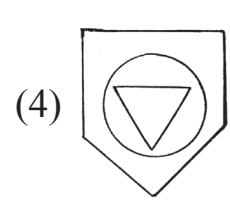
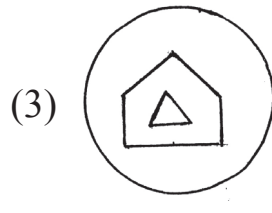
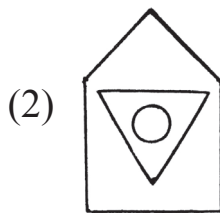
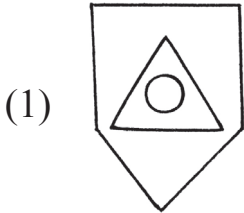
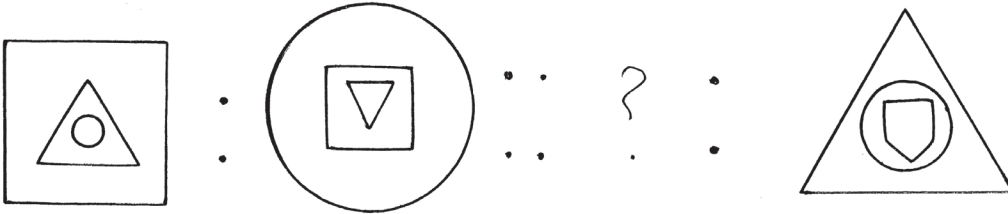

47. खालील संख्यामालेतील अंकांच्या स्थानांची अदलाबदल केल्यानंतर किती मूळसंख्या तयार होतील?

संख्या अक्षरे : 31, 59, 35, 19, 17, 34, 16, 89, 74

(1) 5



(2) 7

(3) 4

(4) 6

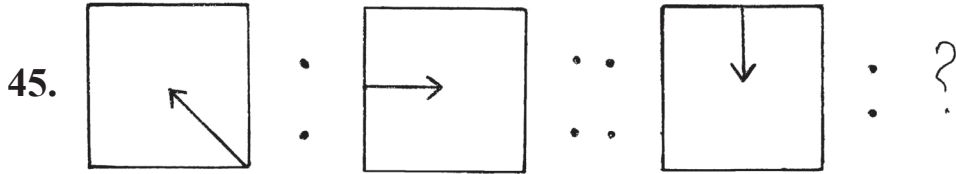
कच्च्या कामासाठी जागा

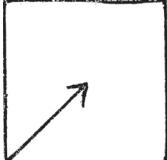
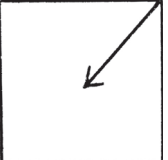
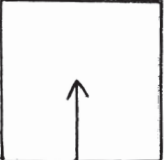

- (1)  (2)  (3)  (4) 

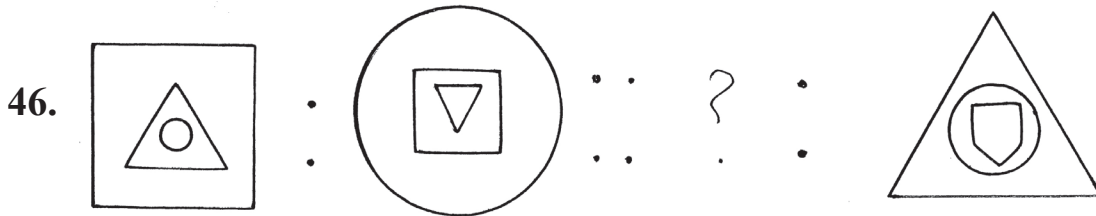

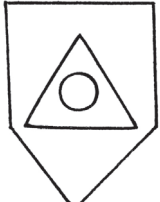
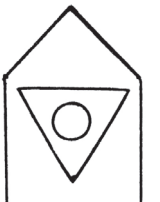
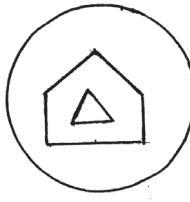
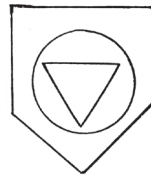
- (1)  (2)  (3)  (4) 

47. By interchanging the digits of the numbers in the given number series how many Prime numbers will form?

Letters: 31, 59, 35, 19, 17, 34, 16, 89, 74

- (1) 5 (2) 7 (3) 4 (4) 6

Space for Rough Work

48. अक्षरमाला : ABCDE FGHIJ KLMNO PQRST UVWXY

वरील अक्षरमालेत 'G' आणि 'R' च्या दरम्यान जेवढी अक्षरे आहेत, त्याच्या $\frac{3}{5}$ पट अक्षरे खालीलपैकी कोणत्या अक्षरांच्या दरम्यान आहेत?

- (1) 'B' आणि 'H' (2) 'K' आणि 'S' (3) 'H' आणि 'O' (4) 'D' आणि 'H'

प्रश्न 49 व 50: साठी सूचना- दिलेल्या प्रश्नाकृतीशी तंतोतंत जुळणारी आकृती पर्यायी उत्तर आकृत्यांमधून निवडा

49. प्रश्नाकृती

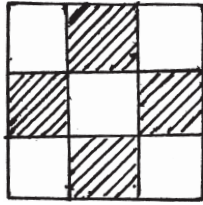

(1)

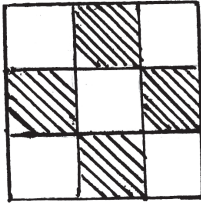

(2)

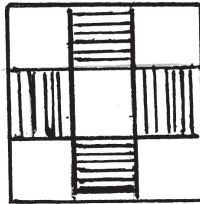

(3)

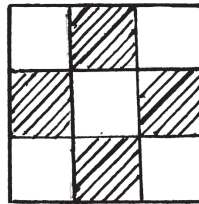

(4)

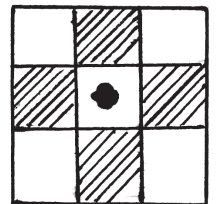

50. प्रश्नाकृती

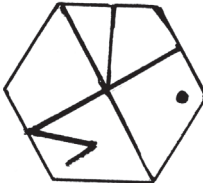

(1)

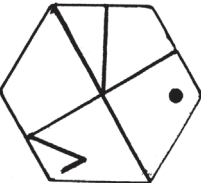

(2)

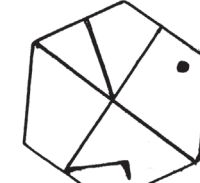

(3)

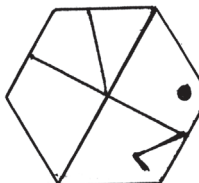

(4)



कच्च्या कामासाठी जागा

48. Alphabetical Series : ABCDE FGHIJ KLMNO PQRST UVWXY

Find out between which two letters the $\frac{3}{5}$ th of the letters between G and R occurs in the above alphabetical series.

- (1) B and H (2) K and S (3) H and O (4) D and H

Instructions for Q. Nos. 49 to 50 : Find out the figure from the alternatives which exactly matches the question figure.

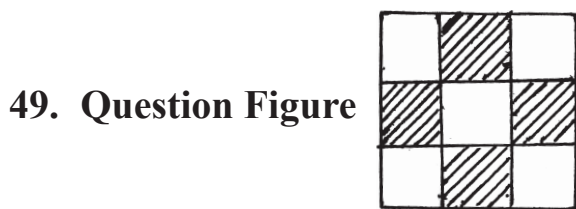

- (1) (2) (3) (4)



- (1) (2) (3) (4)

Space for Rough Work

51. खालील चौकोनात प्रश्नचिन्हाच्या जागी येणारी संख्या पर्यायांतून निवडा.

2	8	5
7	3	9
3	?	4

(1) 1

(2) 0

(3) 6

(4) 10

प्रश्न 52 व 53: साठी सूचना- खालील वेन-आकृतीचे निरीक्षण करून त्यावर आधारित प्रश्नांची उत्तरे पर्यायांतून निवडा.

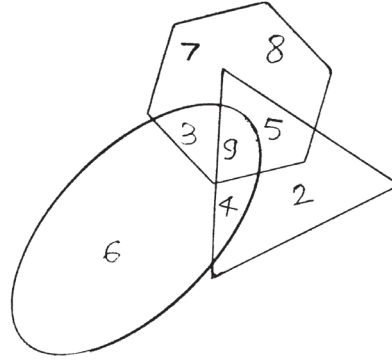

52. फक्त त्रिकोण, फक्त लंबवर्तुळ आणि फक्त षट्कोन यांमधील अंकांची बेरीज किती?

(1) 16

(2) 23

(3) 15

(4) 27

53. तीनही आकृत्यांमध्ये सामाईक असणारा अंक कोणता?

(1) 4

(2) 5

(3) 9

(4) 3

54. एका सांकेतिक भाषेत '5' ला '4', म्हटले '3' ला '7', म्हटले '4' ला '2', म्हटले, तर त्याच सांकेतिक भाषेत-

$$4 + 3 \times 5 = ?$$

(1) 19

(2) 36

(3) 30

(4) 60

कच्च्या कामासाठी जागा

51. See the number arrangement and find the number that will replace the question mark from the alternatives.

2	8	5
7	3	9
3	?	4

- (1) 1 (2) 0 (3) 6 (4) 10

Instructions for Q. Nos. 52 to 53 : Observe the given Venn diagram and answer the questions based on that by selecting the correct alternative.

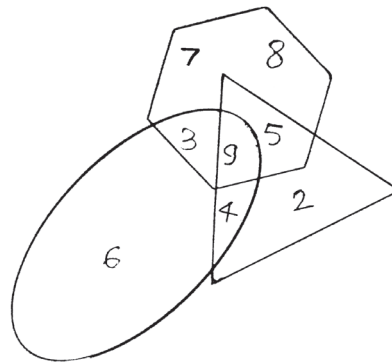

52. What is the total of the numbers given in the triangle, oval and hexagon only?

- (1) 16 (2) 23 (3) 15 (4) 27

53. Which number is common in the three figures?

- (1) 4 (2) 5 (3) 9 (4) 3

54. In a code language '5' is called '4', '3' is called '7', '4' is called '2', then in the same language $4 + 3 \times 5 = ?$ (how much)

- (1) 19 (2) 36 (3) 30 (4) 60

Space for Rough Work

55. एका सांकेतिक भाषेत \otimes म्हणजे $\div 7$ असून

$$14 \otimes \bullet = 10$$

$$3 \bullet \square = 13$$

तर $42 \otimes \square =$ किती?

- (1) 4 (2) 9 (3) 6 (4) 5

प्रश्न 56 ते 60: साठी सूचना- खालील प्रश्नांच्या सुरुवातीला तीन पदे दिली आहेत, त्यांचे काही वैशिष्ट्य आहे, त्यामुळे त्यांचा एक गट तयार होतो. या गटात बसणारे पद पर्यायांतून निश्चित करा.

56. मेंदू, फुफ्फुसे, हृदय :

- (1) जीभ (2) हात (3) यकृत (4) पाय

57. 343, 27, 125 :

- (1) 216 (2) 261 (3) 49 (4) 1

58. 8525, 7612, 9372 :

- (1) 5824 (2) 6083 (3) 3701 (4) 9824

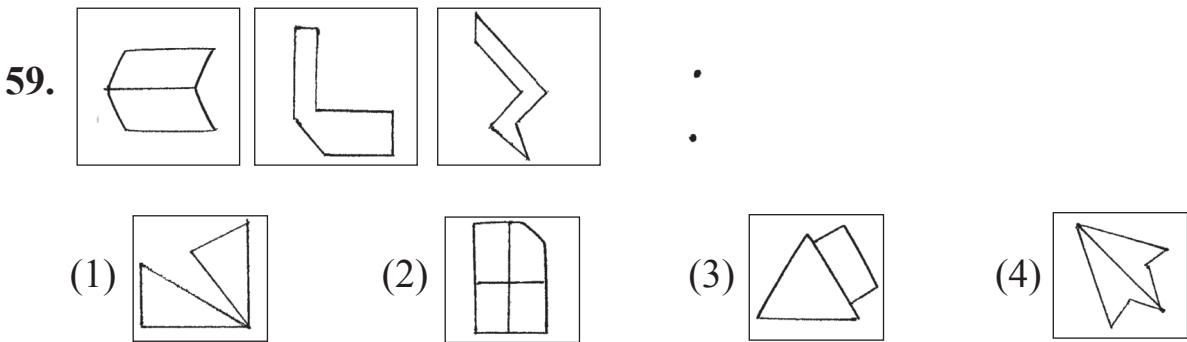

कच्च्या कामासाठी जागा

55. In a code language ⊗ means ÷ 7

like wise $14 \otimes \bullet = 10$

$3 \bullet \square = 13$

Then $42 \otimes \square =$ how much?

- (1) 4 (2) 9 (3) 6 (4) 5

Instructions for Q. Nos. 56 to 60 : In each of the following questions three words are given with some common relation, so their group is formed. Select the word from the alternatives given which has the same common feature of the given group.

56. Brain, Lungs, Heart, _____



- (1) tongue (2) hand (3) liver (4) leg

57. 343, 27, 125, _____

- (1) 216 (2) 261 (3) 49 (4) 1

58. 8525, 7612, 9372, _____

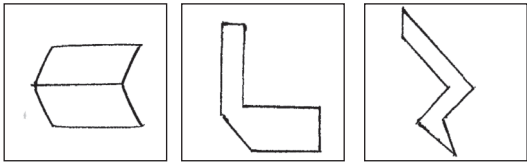
- (1) 5824 (2) 6083 (3) 3701 (4) 9824

59.  .

Space for Rough Work

60.

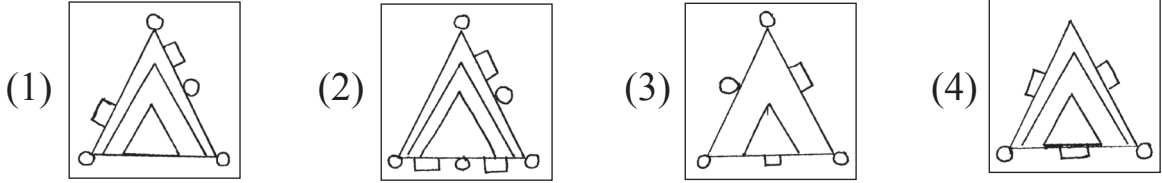
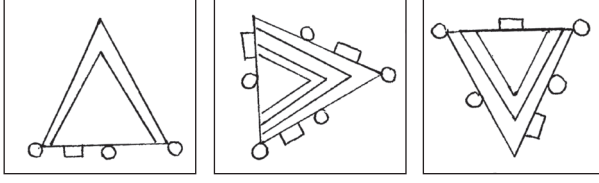

61. खालील सारणीचे निरीक्षण करून त्यावर आधारित प्रश्नाचे उत्तर पर्यायांतून निवडा.

अक्षरे	A	B	C	H	I	O	P	R
चिन्हे	Δ	∇	\bullet	+	\times	<	\neq	=

'POOR' या शब्दाचा विरुद्धार्थी शब्द कसा लिहाल?

- (1) $\neq < < =$ (2) $= \times \bullet +$
 (3) $\angle \neq \Delta \nabla$ (4) $= \times \nabla +$

62. प्रश्नचिन्हाच्या जागी येणारी संख्या पर्यायांतून निवडा.

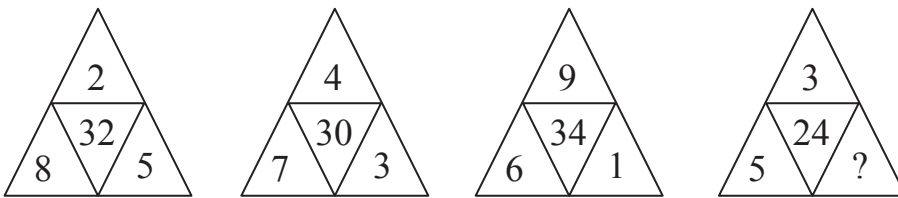

- (1) 2 (2) 5 (3) 4 (4) 3

कच्च्या कामासाठी जागा

63. There is a typical order in the given figures observe them and select the correct alternative to replace the question mark (?)

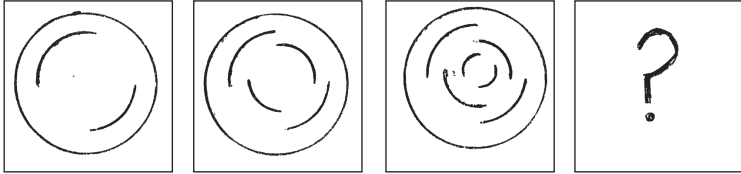

- (1) (2) (3) (4)

64. If elephant is called tiger, tiger is called rabbit, rabbit is called lion, and lion is called bear, then who will be called our national animal?

- (1) tiger (2) rabbit (3) elephant (4) lion

65. Observe the given series and find out which symbols will replace the question mark (?)

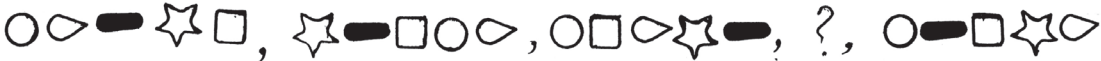

- (1) (2)
 (3) (4)

66. In the given number series find out the odd term.

11, 27, 51, 83, 102, 171

- (1) 51 (2) 27 (3) 171 (4) 102

Space for Rough Work

67. एका सांकेतिक भाषेत BAT = 278, ANT = 276, NET = 765, असे लिहितात, तर त्याच सांकेतिक भाषेत 'BEAN' हा शब्द कसा लिहाल? (अक्षरे व चिन्ह यांचा क्रम सारखाच असतोच असे नाही.)

- (1) 8572 (2) 8526 (3) 7685 (4) 8356

68. खालीलपैकी कोणाची कृती अयोग्य आहे, ते पर्यायांतून निश्चित करा

- (1) अदिती निर्माल्यापासून कंपोस्ट खत तयार करते.
 (2) शर्वीन नेहमी बाजारातून वस्तू प्लॅस्टिक पिशव्यांमधूनच आणतो.
 (3) रूक्साना सामाजिक कार्यात सक्रिय सहभाग घेते.
 (4) पलक प्रदूषणविरोधी जाहिरात करते.

69. मुलाचे आजचे वय आईच्या आजच्या वयाच्या $\frac{1}{2}$ पटीपेक्षा 4 ने कमी असून मावशीच्या आजच्या वयाच्या $\frac{1}{3}$ पटीपेक्षा 2 ने जास्त आहे. जर आईचे आजचे वय 42 वर्षे असल्यास मावशीचे दोन वर्षापूर्वीचे वय किती वर्षे असेल?

- (1) 43 (2) 45 (3) 47 (4) 40

70. खालील आकृतीत एकूण त्रिकोण किती आहेत?

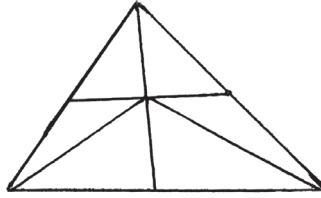

- (1) 9 (2) 13 (3) 15 (4) 12

71. पाच जणांच्या धावण्याच्या शर्यतीत जॉनच्या पुढे अहमद होता. अहमद व समीरच्या दरम्यान फक्त गौतम असून जॉन व अहमदच्या दरम्यान हरभजन होता, तर मध्यभागी कोण होता?

- (1) जॉन (2) समीर (3) गौतम (4) अहमद

कच्च्या कामासाठी जागा

67. In a code language BAT = 278, ANT = 276, NET = 765, then in the same code how 'BEAN' is written? (It is not necessary that the order of the letters and number is same.)

- (1) 8572 (2) 8526 (3) 7685 (4) 8356

68. From the given statements whose activity is incorrect. Choose the correct alternative.

- (1) Aditi prepares compost manure from the dried flowers and leaves.
 (2) Sharvin always brings things from the market in plastic bags.
 (3) Rukhsana actively participates in the social activities.
 (4) Palak promotes antipollution advertisement.

69. A son's present age is 4 less than $\frac{1}{2}$ of the mother's present age and 2 more than $\frac{1}{3}$ rd of the aunt's present age. If the present age of his mother is 42 years then what was the age of his aunt two years ago?

- (1) 43 (2) 45 (3) 47 (4) 40

70. How many triangles are there in the given figure?

- (1) 9
 (2) 13
 (3) 15
 (4) 12

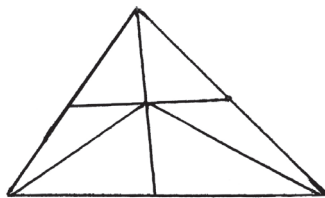

71. In a running race of 5 students, Ahmed was ahead of John. Gautam was between Ahmed and Sameer. Harbhajan was between John and Ahmed. who was at the centre?

- (1) John (2) Sameer (3) Gautam (4) Ahmed

Space for Rough Work

72. खालील आकृतीत दर्शविल्याप्रमाणे समान आकाराच्या घनाकृती ठोकळ्यांची मांडणी करून एक प्रतिकृती तयार केली; तर तिला एकूण किती पृष्ठे असतील?

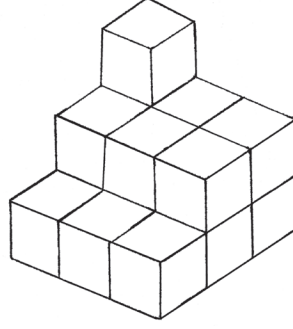

- (1) 12 (2) 8 (3) 10 (4) 11

73. एका 1.5 किमी लांबीच्या रस्त्याच्या कडेने दुतर्फा 60 मी. अंतरावर एक विजेचा खांब, या प्रमाणे विजेचे खांब लावल्यास एकूण किती खांब लागतील?

- (1) 25 (2) 26 (3) 50 (4) 52

74. खालील आकृतीत चौकोनांची संख्या किती?

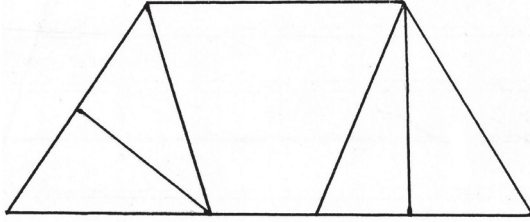

- (1) 5 (2) 4 (3) 7 (4) 6

75. शिक्षक वर्गात नसताना वर्गातील दोन मुलांचे भांडण सुरू झाले; तर तुम्ही वर्गप्रमुख म्हणून प्रथम कोणती कृती कराल?

- (1) ते दोघे कसे भांडतात ते पाहत राहिन.
 (2) भांडणाचा विषय वर्गशिक्षकांच्या कानावर घालेन.
 (3) दोघांची समजूत घालून भांडण सोडविण्याचा प्रयत्न करेन.
 (4) त्या दोघांचा निषेध करेन.

कच्च्या कामासाठी जागा

72. The clues of same dimension are arranged according to the given figure and a new figure is formed. How many faces will be there of such figure?

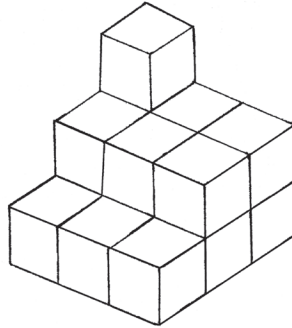

- (1) 12 (2) 8 (3) 10 (4) 11

73. If the electric poles are erected at 60m distance on 1.5 km long road on both the sides, how many poles will be erected?

- (1) 25 (2) 26 (3) 50 (4) 52

74. What is the number of quadrilaterals in the adjacent figure?

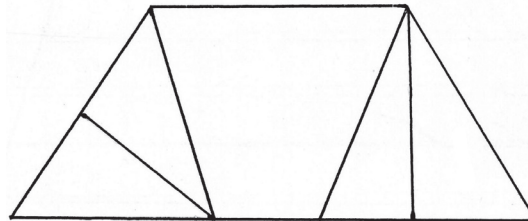

- (1) 5 (2) 4 (3) 7 (4) 6

75. The teacher is not in the class and two students enter into a quarrel. What will you do as a monitor?

- (1) You will see how they fight.
 (2) Inform the subject of fight to the class teacher.
 (3) You will convince them and try to sort out the issue.
 (4) You will prohibit both of them.

Space for Rough Work

Space for Rough Work